

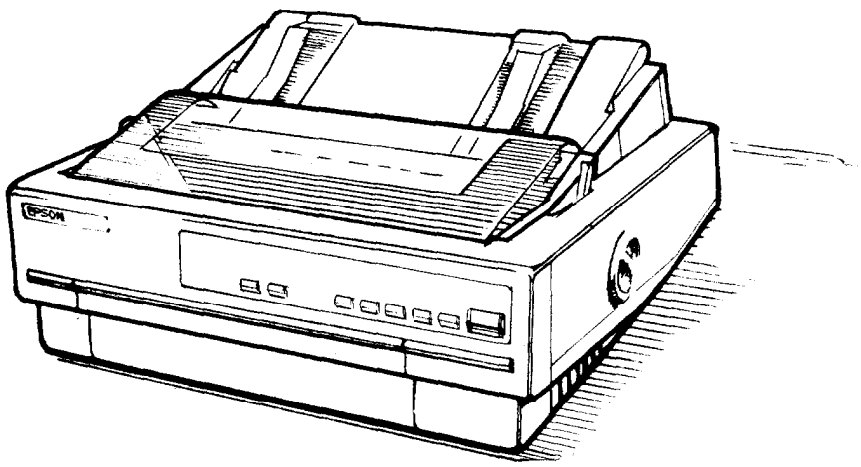

# EPSON<sup>®</sup> *ActionPrinter*<sup>™</sup>

5000/5500



U S E R ' S M A N U A L

# EPSON® *ActionPrinter*™ 5000/5500

No part of this publication may be reproduced, stored in a retrieval system, or transmitted in **any** form or by any means, mechanical, photocopying, recording, or otherwise, without the prior written permission of Seiko Epson Corporation. No patent liability is assumed with respect to the use of the information contained herein. While every precaution has been taken in the preparation of this book, Seiko Epson Corporation assumes no responsibility for errors or omissions. Neither is any liability assumed for damages resulting from the use of the information contained herein.

Neither Seiko Epson Corporation nor its affiliates shall be liable to **the** purchaser of this product or third parties for damages, losses, costs, or expenses incurred by purchaser or third parties as a result of: accident, misuse, or abuse of this product or unauthorized modifications, repairs, or alterations to this product.

Seiko Epson Corporation and its affiliates shall not be liable against any damages or problems arising from the use of any options or **any** consumable products other than those designated as Original Epson Products or Epson Approved Products by Seiko Epson Corporation.

Epson and Epson ESC/P are registered trademarks and Epson ESC/P 2 is a trademark of Seiko Epson Corporation.

General Notice: Other product names used herein are for identification purposes only and may be trademarks of their respective companies.

Copyright © 1991 by Epson America, Inc., Torrance, California. All rights reserved

## **For United States Users**

This equipment has been tested and found to comply with the limits for a Class B digital device, pursuant to Part 15 of the FCC Rules. These limits are designed to provide reasonable protection against harmful interference in a residential installation. This equipment generates, uses and can radiate radio frequency energy and, if not installed and used in accordance with the instructions, may cause harmful interference to radio or television reception. However, there is no guarantee that interference will not occur in a particular installation. If this equipment does cause interference to radio and television reception, which can be determined by turning the equipment off and on, the user is encouraged to try to correct the interference by one or more of the following measures.

- Reorient or relocate the receiving antenna
- Increase the separation between the equipment and receiver
- Connect the equipment into an outlet on a circuit different from that to which the receiver is connected
- Consult the dealer or an experienced radio/TV technician for help.

## **WARNING**

The connection of a non-shielded equipment interface cable to this equipment will invalidate the FCC Certification of this device and may cause interference levels which exceed the limits established by the FCC for this equipment. It is the responsibility of the user to obtain and use a shielded equipment interface cable with this device. If this equipment has more than one interface connector, do not leave cables connected to unused interfaces.

Changes or modifications not expressly approved by the manufacturer could void the user's authority to operate the equipment.

## **For Canadian Users**

This digital apparatus does not exceed the Class B limits for radio noise emissions from digital apparatus as set out in the radio interference regulations of the Canadian Department of Communications.

Le présent appareil numérique n'émet pas de bruits radioélectriques dépassant les limites applicables aux appareils numériques de Classe B prescrites dans le règlement sur le brouillage radioélectrique édicté par le Ministère des Communications du Canada.

## TIPS FOR PRINTING ON SINGLE SHEETS

There are a few things you should know about printing on single sheets as opposed to continuous paper. When you print on single sheets, you may notice that your printer prints the first page of your file correctly but then prints too low on the next page, or that it prints the last few lines from one page onto the next.

These differences in print position are easy to adjust; you can simply change some of the settings in your application program as described below to get the right results.

1. When you install an application program, it normally asks you what printer you are using. Make sure you choose the correct printer. See Chapter 1 for the right printer to choose.
2. Many programs include an option to set the maximum lines per page. If your program has a lines-per-page setting and you are using standard 8½ x 11-inch paper, set the lines per page to 61.

Note: To find the right lines-per-page setting for paper that is not 8½ x 11, create a test document using your application program. Set your top and bottom margins to 0 and then create a file of numbered lines from 1 to 66. When you print your file, notice the last number printed on the first page. This is your maximum lines-per-page setting.

3. If your program doesn't have a lines-per-page setting, try decreasing the top margin or increasing the bottom margin, or both, until you get the results you want.
4. You can also try adjusting the form length setting. For a standard 8½ x 11-inch page, try setting the form length at 10 inches.
5. Some programs also let you indicate whether you are using single sheets or continuous paper. Make sure you choose single sheets.

## **Where to Get Help for United States Users**

Epson America provides customer support and service through a network of authorized Epson dealers and Customer Care Centers throughout the United States.

You can call Epson's Technical Support Center for assistance with installation, configuration, and operation of Epson products, at (900) 988-4949, Monday through Friday between 7:00 a.m. and 4:00 p.m. Pacific time.

For the location of your nearest Epson dealer or Customer Care Center, call the Epson Consumer Information Center at **(213) 782-2606**.

# **IMPORTANT SAFETY INSTRUCTIONS**

1. Read all of these instructions and save them for later reference.
2. Follow all warnings and instructions marked on the product.
3. Unplug this product from the wall outlet before cleaning. Do not use liquid cleaners or aerosol cleaners. Use a damp cloth for cleaning.
4. Do not use this product near water.
5. Do not place this product on an unstable cart, stand, or table. The product may fall, causing serious damage to the product.
6. Slots and openings in the cabinet and the back or bottom are provided for ventilation; to ensure reliable operation of the product and to protect it from overheating, these openings must not be blocked or covered. The openings should never be blocked by placing the product on a bed, sofa, rug, or other similar surface. This product should never be placed near or over a radiator or heat register. This product should not be placed in a built-in installation unless proper ventilation is provided.
7. This product should be operated from the type of power source indicated on the marking label. If you are not sure of the type of power available, consult your dealer or local power company.
8. This product is equipped with a 3-wire grounding-type plug, a plug having a third (grounding) pin. This plug will only fit into a grounding-type power outlet. This is a safety feature. If you are unable to insert the plug into the outlet, contact your electrician to replace your obsolete outlet. Do not defeat the purpose of the grounding-type plug.
9. Do not locate this product where the cord will be walked on.

- 10.** If an extension cord is used with this product, make sure that the total of the ampere ratings on the products plugged into the extension cord does not exceed the extension cord ampere rating. Also, make sure that the total of all products plugged into the wall outlet does not exceed 15 amperes.
- 11.** Never push objects of any kind into this product through cabinet slots as they may touch dangerous voltage points or short out parts that could result in a risk of fire or electric shock. Never spill liquid of any kind on the product.
- 12.** Except as specifically explained in the User's Manual, do not attempt to service this product yourself. Opening or removing those covers that are marked "Do Not Remove" may expose you to dangerous voltage points or other risks. Refer all servicing in those compartments to service personnel.
- 13.** Unplug this product from the wall outlet and refer servicing to qualified service personnel under the following conditions:
  - A. When the power cord or plug is damaged or frayed.
  - B. If liquid has been spilled into the product.
  - C. If the product has been exposed to rain or water.
  - D. If the product does not operate normally when the operating instructions are followed. Adjust only those controls that are covered by the operating instructions since improper adjustment of other controls may result in damage and will often require extensive work by a qualified technician to restore the product to normal operation.
  - E. If the product has been dropped or the cabinet has been damaged.
  - F. If the product exhibits a distinct change in performance, indicating a need for service.

---

# Contents

<b>Introduction</b>	<b>1</b>
Features .....	1
Options.. .....	2
Finding Your Way Around .....	3
Warnings, Cautions, and Notes .....	3
Printer Parts .....	4
<b>Chapter 1 Setting Up the Printer</b>	<b>1-1</b>
Unpacking the Printer .....	1-2
Choosing a Place for the Printer .....	1-3
Assembling the Printer .....	1-5
Testing the Printer .....	1-10
Connecting the Printer to Your Computer .....	1-13
Configuring Your Software for the Printer .....	1-14
<b>Chapter 2 Paper Handling</b>	<b>2-1</b>
Selecting a Paper Feeding Method .....	2-2
Using Single Sheets .....	2-4
Using Continuous Paper .....	2-9
Switching Between Continuous Paper and Single Sheets . . .	2-21
Printing on Special Paper .....	2-23
<b>Chapter 3 Using the Printer</b>	<b>3-1</b>
Control Panel .....	3-2
DIP Switches .....	3-6
Micro Feed .....	3-13
Tear Off .....	3-16
Typestyles .....	3-19
Data Dump Mode .....	3-24



<b>Chapter 4 Using Printer Options</b>	<b>4-1</b>
<hr/>	
Cut-Sheet Feeders .....	4-2
Pull Tractor .....	4-12
Interface Cards .....	4-14
<b>Chapter 5 Maintenance and Transportation</b>	<b>5-1</b>
<hr/>	
Cleaning the Printer .....	5-2
Replacing the Ribbon Cartridge .....	5-3
Transporting the Printer .....	5-4
<b>Chapter 6 Troubleshooting</b>	<b>6-1</b>
<hr/>	
Problems and Solutions .....	6-2
Power Supply .....	6-3
Printing .....	6-4
Paper Handling .....	6-8
Options .....	6-10
<b>Chapter 7 Technical Specifications</b>	<b>7-1</b>
<hr/>	
Printer Specifications .....	7-2
Interface Specifications .....	7-10
Option Specifications.. ..	7-14
Initialization.. ..	7-16
<b>Chapter 8 Command Summary</b>	<b>8-1</b>
<hr/>	
Using the Command Summary .....	8-2
Commands Arranged by Topic.....	8-3
<b>Appendix</b>	<b>A-1</b>
<hr/>	
Character Tables .....	A-2
International Character Sets.....	A-6
<b>Glossary</b>	<b>GL-1</b>
<hr/>	
<b>Index</b>	<b>IN-1</b>
<hr/>	

---

# Introduction

Your new Epson™ printer is an advanced 24-pin dot matrix printer that combines high performance with a wide range of features.

## Features

These features make your Epson printer an outstanding value:

- Fast printing speed. You can print up to 252 characters per second in 12 cpi draft mode.
- Easy paper handling. The printer has four paper paths to suit your printing needs: top, rear, bottom, and front.
- Automatic paper loading. The printer automatically loads single sheets and continuous paper.
- Epson ESC/P 2. This enhanced printer control language adds scalable fonts and improved graphics capability. With scalable fonts, you can print characters of various sizes.
- Compatibility. The printer supports the Epson ESC/P® commands widely used in application programs written for other Epson LQ and SQ printers.
- Unique control-panel design. You can choose from nine popular letter-quality fonts and one draft font.

The ActionPrinter 5000 and ActionPrinter 5500 are basically the same printer except for the width of their carriages. The ActionPrinter 5000 has a standard width carriage that accommodates paper up to 254 mm (10 inches) wide. The ActionPrinter 5500 has a wide carriage that accommodates paper up to 355.6 mm (14 inches) wide.

## Options

You may choose from several printer options to enhance your printer. For more information on these options, see Chapter 4.

- **Single-Bin Cut-Sheet Feeder**  
(C80637\* for ActionPrinter 5000, C80639\* for ActionPrinter 5500)  
This economical cut-sheet feeder automatically feeds up to **50** sheets of **paper** into your printer without reloading. You can load continuous paper and manually load single sheets without removing the cut-sheet feeder.
- **High-Capacity Cut-Sheet Feeder**  
(C80638\* for ActionPrinter 5000, C80640\* for ActionPrinter 5500)  
This cut-sheet feeder automatically feeds up to **150** sheets of paper or **25** plain bond envelopes without reloading. You can create a double-bin cut-sheet feeder by connecting this cut-sheet feeder to the single-bin model.
- **Pull-Tractor Unit**  
(C80019\* for ActionPrinter 5000, C80022\* for ActionPrinter 5500)  
Although you can use the standard tractor as a pull tractor, using the optional pull tractor improves printing accuracy, which is especially useful for printing on continuous multi-part forms.
- **Film Ribbon Cartridge**  
(#7768 for ActionPrinter 5000, #7770 for ActionPrinter 5500)  
An optional film ribbon cartridge provides even higher quality printing than the standard fabric ribbon.
- **Interface Cards**  
Optional interface cards are available to supplement the printer's built-in parallel interface. Guidelines for choosing the right interface and instructions on installing the cards are given in Chapter 4.

The last figure in option part numbers, represented by an asterisk (\*), varies by country. Contact your local Epson dealer for the part number in your country.

## Finding Your Way Around

This manual provides fully illustrated, step-by-step instructions for setting up and operating your printer.

- Chapter 1 contains information on unpacking, setting up, testing, and connecting the printer. Be sure to read this chapter first.
- Chapters 2 and 3 include important information on paper handling and day-to-day operation of your printer.
- Chapter 6 contains troubleshooting information. If the printer does not operate properly or the printed results are not what you expect, see Chapter 6 for a list of problems and solutions.
- Other chapters contain information on options, general maintenance, specifications, and printer commands. See the end of this manual for a glossary of printer terms and an index.

## Warnings, Cautions, and Notes



**WARNINGS** must be followed to avoid bodily injury.



**CAUTIONS** must be observed to avoid damage to your equipment.

Notes contain important information and useful tips on the operation of your printer.

## Printer Parts

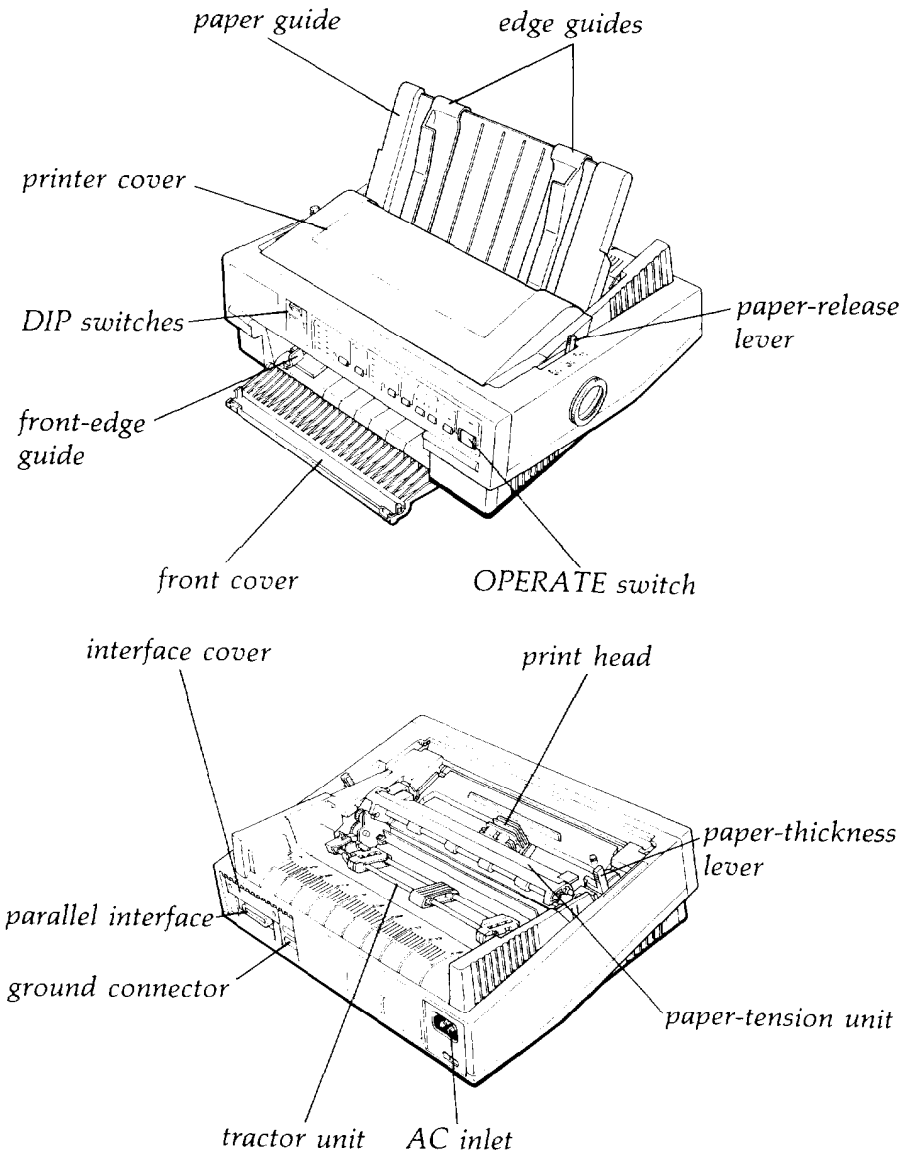

**Chapter 1**

---

**Setting Up the Printer**

Unpacking the Printer ..... 1-2  
    Checking the parts ..... **1-2**

Choosing a Place for the Printer ..... 1-3

Assembling the Printer ..... 1-5  
    Removing the protective materials ..... 1-5  
    Installing the ribbon cartridge ..... 1-6  
    Attaching the paper guide ..... 1-9

Testing the Printer ..... 1-10  
    Plugging in the printer ..... 1-10  
    Running the self test ..... 1-10

Connecting the Printer to Your Computer ..... 1-13

Configuring Your Software for the Printer ..... 1-14  
    Choosing from a menu ..... 1-14

---

## Unpacking the Printer

### Checking the parts

When you unpack the printer, make sure you have all the parts shown below and that none is damaged.

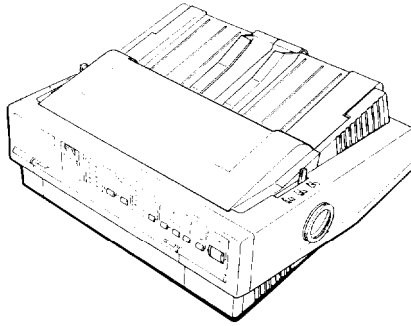

Printer

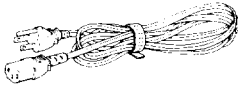

Power cord

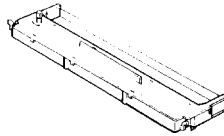

Ribbon cartridge

Note: In some locations the power cord may be attached to the printer.

Store the packing materials in case you ever need to transport your printer.



**CAUTION:** There are several versions of the printer designed for different voltages, and it is not possible to adjust the printer for use at another voltage. If the label on the back of the printer does not show the correct voltage for your country, contact your dealer.

---

## Choosing a Place for the Printer

When selecting a place to set up your printer, be sure to follow the guidelines below.

- Place the printer on a flat, stable surface.
- Place the printer close enough to the computer for the printer's interface cable to reach it.
- Leave adequate room around the printer to allow for easy operation and maintenance.



**CAUTION:** Avoid locations that are subject to direct sunlight, excessive heat, moisture, or dust.

- Use a grounded outlet; do not use an adapter plug.
- Place the printer where you can easily unplug the power cord.
- Avoid electrical outlets controlled by wall switches or automatic timers. Accidental disruption of power can wipe out information in the memory of your printer or computer.
- Avoid outlets on the same circuit as large motors or other appliances that can cause fluctuations in line voltage.
- Keep the entire computer system away from potential sources of electromagnetic interference, such as loudspeakers or the base units of cordless telephones.



If you plan to use a printer stand, follow these guidelines:

- Use a stand that supports at least 16.0 kg (35.3 lbs) for the ActionPrinter 5000 or 22.0 kg (48.5 lbs) for the ActionPrinter 5500.
- Never use a stand that tilts the printer at an angle of more than 15 degrees from horizontal. If you install a cut-sheet feeder, the stand must keep your printer level.
- If you plan to load continuous paper through the bottom of the printer, choose a stand that provides an unobstructed paper path.
- Position your printer's power cord and interface cable so they do not interfere with paper feeding. If possible, secure the cables to a leg of the printer stand.
- Align the paper stack so that the paper feeds straight into the tractor's sprocket units.

---

## Assembling the Printer

### Removing the protective materials

During shipping, packing materials protect the printer and a locking clip protects the paper-tension unit. Before you turn on the printer, you must remove the locking clip as described here:

1. Remove the paper guide. Lift the printer cover up and off.  
Grasp both ends of the clear plastic paper-tension unit; lift up the front of the unit and then lift it off.

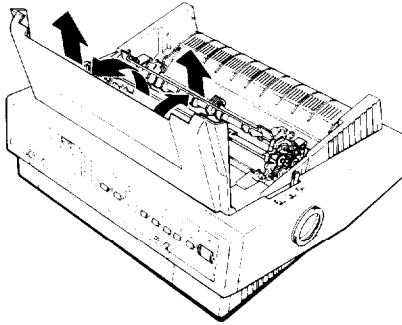

2. Remove the locking clip from the paper-tension unit.

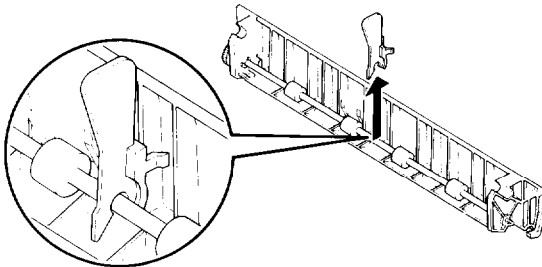

**Note:** Store the clip with the other packing materials in case you ever need to transport your printer.

## **Installing the ribbon cartridge**

Before installing the ribbon cartridge, make sure that the power cord is not plugged into an electrical outlet.

1. If necessary, lift the printer cover up and off. Grasp both ends of the clear plastic paper-tension unit and lift it up and off also,

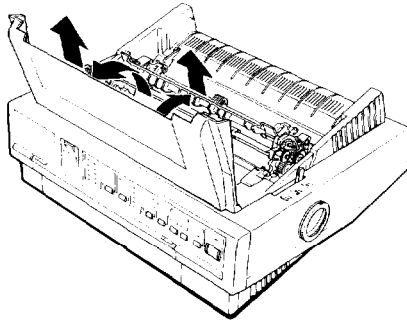

**WARNING:** Never move the print head while the printer is turned on; this can damage the printer. Also, if you just used the printer, the print head may be hot. Let it cool for a few minutes before touching it.

2. Slide the print head to the middle of the printer.

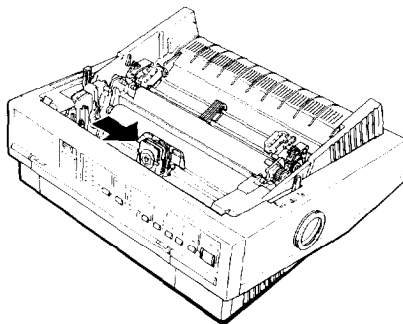

3. Turn the ribbon-tightening knob in the direction of the arrow. This removes any slack in the ribbon and makes it easier to install. Next, hold the ribbon cartridge by its handle and push it firmly down into position; then press on both ends of the cartridge to make sure the plastic hooks fit into the slots.

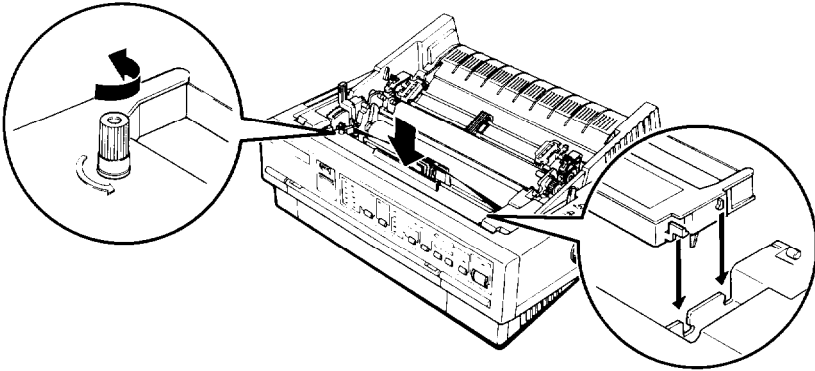

4. Use a pointed object, such as a ball point pen, to guide the ribbon between the print head and ribbon guide. Turn the ribbon-tightening knob to help feed the ribbon into place.

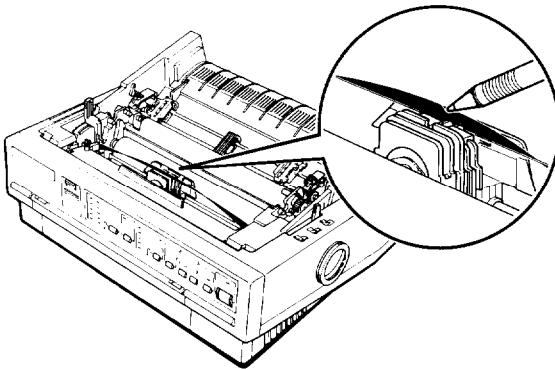

5. Slide the print head from side to side to make sure it moves smoothly. Also check that the ribbon is not twisted or creased.

6. Replace the paper-tension unit by placing it **on** the printer's mounting pegs; then lower the front of the unit into place. Press on the front of both sides of the paper-tension unit until you feel it click into place.

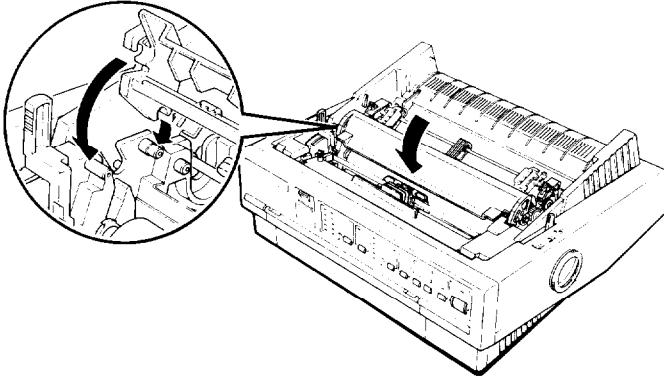

7. Replace the printer cover by first inserting the front tabs into the slots on the printer; then lower it into place.

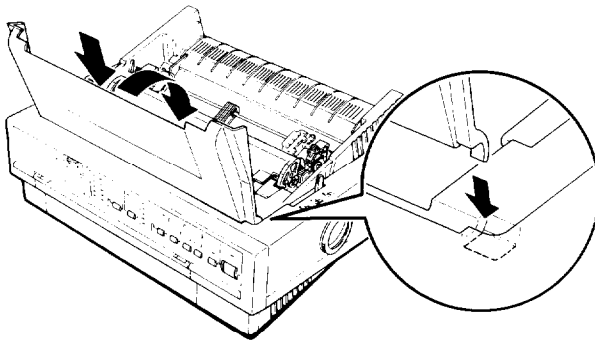

Note: You install the optional #7768 or #7770 film ribbons in the same way as you install the ribbon cartridge. However, you should follow the guidelines below when using a film ribbon:

- Print on ordinary paper only.
- Move the paper-thickness lever to the next lowest position.

## **Attaching the paper guide**

1. Place the notches on the paper guide straight down over the mounting posts on the printer.

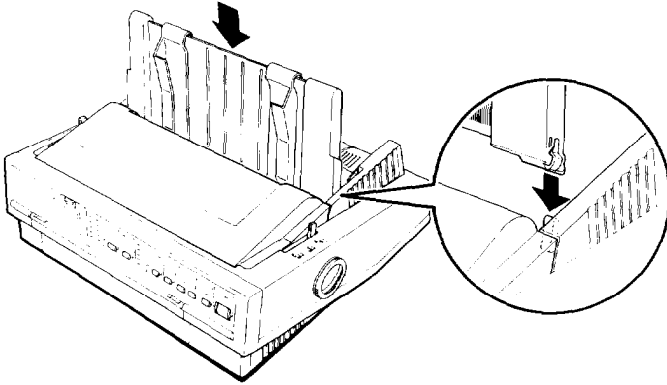

2. Lower the paper guide until it stops in the upright position.

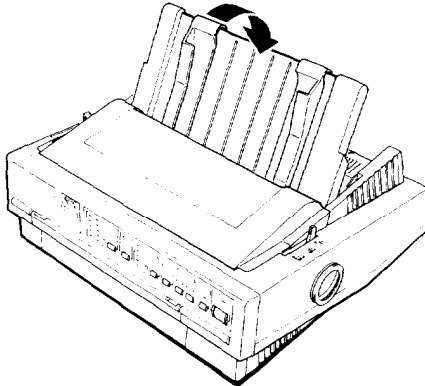

---

## Testing the Printer

Before connecting your printer to a computer, use the built-in self-test function to see that the printer is working properly.

Before running the self test, you need to plug your printer's power cord into an electrical outlet.

### Plugging in the printer

1. Make sure the printer is turned off.
2. Check the label on the back of the printer to make sure the voltage required by the printer **matches that** of your electrical outlet.



**CAUTION:** If the rated voltage and your outlet voltage do not match, contact your dealer for assistance. Do not plug in the power cord.

3. If the power cord is not attached to the printer, connect it to the AC inlet on the printer's rear panel.
4. Plug the power cord into a properly grounded electrical outlet.

### Running the self test

You can run the self test with either continuous paper or single sheets. Also, you can load the paper for the test from the top, rear, front, or bottom. The following steps describe how to run the test on single-sheet paper, loaded from the top. See Chapter 2 for full details on paper handling.

The self test begins by printing on the first and last lines of page 1. The printer then prints the DIP-switch settings and character samples on page 2.

The printer prints the self test in the currently selected font.

1. Make sure the printer is turned off and that the paper-release lever is in the single-sheet position.

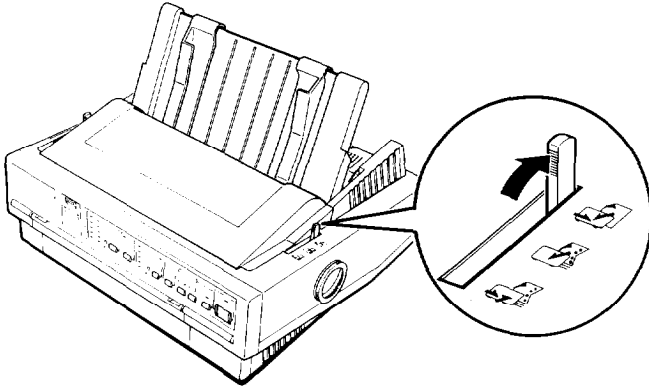

2. While holding down the LF/FF (Line Feed/Form Feed) button, turn on the printer. The printer beeps and the platen turns for a few seconds, signalling that the printer is in self-test mode.
3. Move the left edge guide until it locks in place next to the guide mark. Then adjust the right edge guide to match the width of your paper.

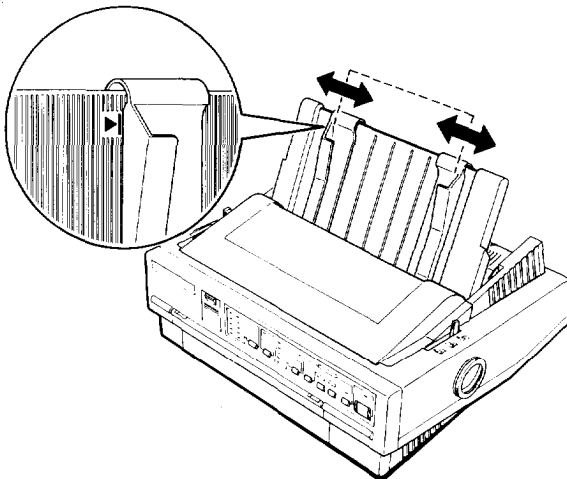





**CAUTION:** Run the self test using paper at least 210 mm (8.2 inches) wide for the ActionPrinter 5000 or 360 mm (14 inches) wide for the ActionPrinter 5500; otherwise, the print head prints directly on the platen.

4. Insert a sheet of paper between the edge guides until it meets resistance. After a few seconds, the printer loads the paper to the loading position and begins printing the self test.

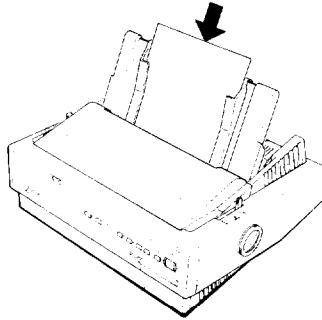

5. To stop the self test, press the **PAUSE** button (you can resume the self test by pressing the **PAUSE** button again).
6. Press the **LOAD/EJECT** button to eject the paper from the printer and then turn the printer off.

**Note:** If test results are not satisfactory, see Chapter 6.

Here is part of a typical self test.

Roman

! " # \$ % & ' ( ) \* + , - . / 0 1 2 3 4 5 6 7 8 9 ; : < = > ? @ A B C D E F G H I J K L  
! " # \$ % & ' ( ) \* + , - . / 0 1 2 3 4 5 6 7 8 9 ; : < = > ? @ A B C D E F G H I J K L M  
" # \$ % & ' ( ) \* + , - . / 0 1 2 3 4 5 6 7 8 9 ; : < = > ? @ A B C D E F G H I J K L M N  
# \$ % & ' ( ) \* + , - . / 0 1 2 3 4 5 6 7 8 9 ; : < = > ? @ A B C D E F G H I J K L M N O  
\$ % & ' ( ) \* + , - . / 0 1 2 3 4 5 6 7 8 9 ; : < = > ? @ A B C D E F G H I J K L M N O P

---

## Connecting the Printer to Your Computer

If the self test prints correctly, you are ready to connect your printer to the computer. Use a shielded twisted-pair parallel cable to connect your computer to the printer's built-in parallel interface.

Connect the parallel interface cable as described below:

1. Make sure both the printer and computer are turned off; then plug the cable connector securely into the printer's parallel interface connector. Squeeze the wire clips together until they lock in place on either side of the connector.

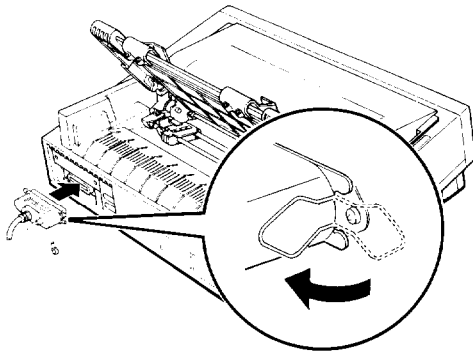

**Note:** If your **cable** has a ground wire, connect it to the ground connector beside the interface connector.

2. Plug the other end of the **cable** into the computer. (If there is a ground wire at **the** computer end of the cable, attach it to the ground connector at the back of the computer.)

---

## Configuring Your Software for the Printer

Most application programs let you specify the type of printer you use so that the program can take full advantage of the printer's features. Many of these programs provide an installation or setup section that presents a list of printers.

### Choosing from a menu

Because Epson printers share a great many commands, you can use an application program even if it does not list your printer on its printer selection menu. Choose from the following list (the printers are listed in the order of preference):

**LQ-570/1070**

**LQ-510/550**

**LQ-500**

**LQ-860 (LQ-1060)**

**LQ-850 (LQ-1050)**

**LQ-2550**

**LQ-2500**

**LQ-800 (LQ-1000)**

**LQ-1500**

If none of these printers is listed, select the first one available from the following list:

**EX, FX, LX, RX, MX, Epson printer, Standard printer, Draft printer.**

To use all the features of your printer, however, it is best to choose a program with your printer on its menu. If your program does not list this printer, contact the manufacturer of the software to see if an update that supports the ActionPrinter **5000/5500** is available.

## Chapter 2

---

# Paper Handling

Selecting a Paper Feeding Method .....	2-2
Setting the paper-release lever .....	2-2
Using Single Sheets .....	2-4
Loading single sheets from the top .....	2-4
Loading single sheets from the front .....	2-6
Using Continuous Paper .....	2-9
Tractor position and available paper paths .....	2-9
Changing tractor positions .....	2-10
Loading continuous paper with the push tractor .....	2-12
Removing continuous paper from the push tractor .....	2-14
Loading continuous paper with the pull tractor.....	2-15
Removing continuous paper from the pull tractor .....	2-20
Switching Between Continuous Paper and Single Sheets . . .	2-21
Switching to single sheets .....	2-21
Switching to continuous paper.....	2-22
Printing on Special Paper .....	2-23
Paper-thickness lever .....	2-23
Multi-part forms .....	2-24
Labels .....	2-25
Envelopes .....	2-26

---

## Selecting a Paper Feeding Method

Your printer can feed single sheets from the top and front and continuous paper from the rear, front, and bottom. Also, you can use the tractor unit for continuous paper as either a push or pull tractor.

You will probably use only one or two of these methods on a regular basis.

This chapter explains the various methods of paper handling and includes recommendations on the feeding methods best suited to your specific needs.

### Setting the paper-release lever

The paper-release lever has three positions, with icons indicating the type of paper and paper path for each position.

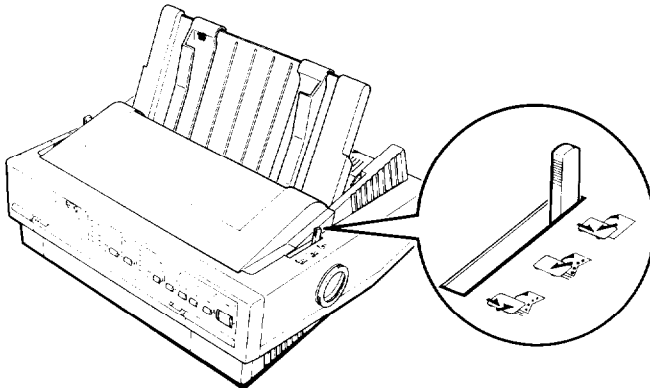

Single sheet This position is for loading single sheets.



Push tractor This position is for loading continuous paper from the rear, with the tractor in the push-tractor position.



Pull tractor This position is for loading continuous paper from the rear, front, or bottom, with the tractor in the pull-tractor position. Use this position when you have installed both the push tractor and the optional pull tractor.

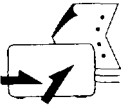

---

## Using Single Sheets

Your printer can print on single sheets of paper from 148 mm (5.8 inches) to **257 mm** (10.1 inches) wide on the ActionPrinter 5000 and from **148 mm** (**5.8 inches**) to **420 mm** (**16.5 inches**) wide on the ActionPrinter 5500.

You can load single sheets from either the top or front of the printer.

### Loading single sheets from the top

1. Move the paper-release lever to the single-sheet position. Make sure the paper guide is in the upright position.

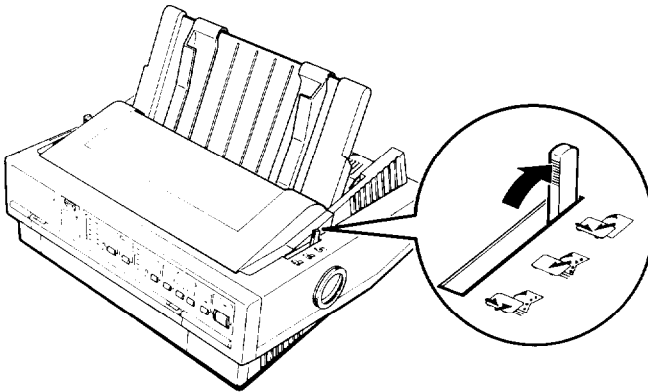

2. Turn on the printer. The **OPERATE** light on the control panel comes on.

3. Slowly slide the left edge guide until it stops next to the arrow on the paper guide. Then adjust the right edge guide to match the width of your paper.

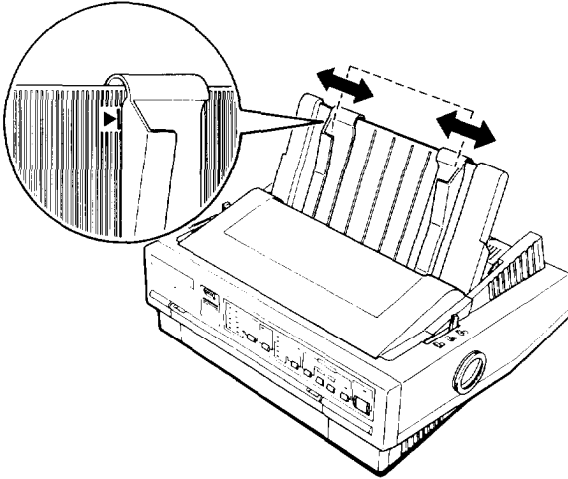

4. Insert the paper firmly between the edge guides until it meets resistance; after a few seconds, the printer automatically advances the paper to the loading position.

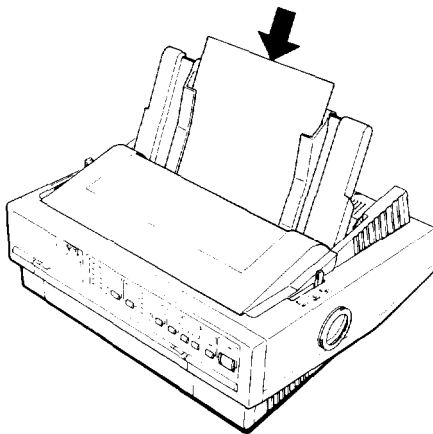





**CAUTION:** Use the knob on the right side of the printer only to clear paper jams when the printer is off. Otherwise, you may damage the printer or cause it to lose the top-of-form position.

If the platen turns but the printer doesn't load the paper, completely remove the paper and re-insert it more firmly.

To eject the paper, press the **LOAD/EJECT** button.

### **Loading single sheets from the front**

1. Move the paper-release lever to the single-sheet position and open the front cover.

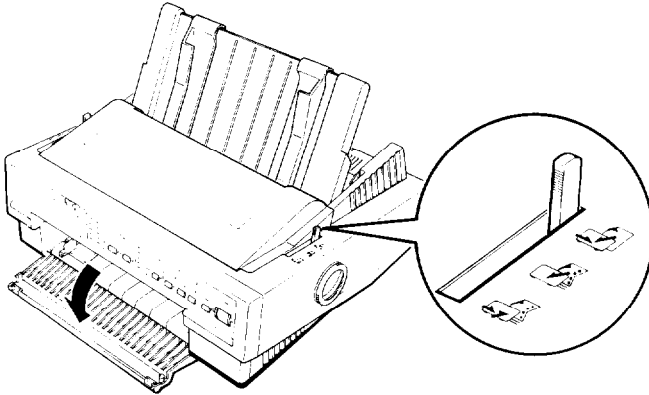

2. Turn on the printer. The **OPERATE** light on the control panel comes on.

3. Slide the edge guide until you feel it click into place at the guide mark. You can slide the edge guide to the left in 1/10-inch increments to increase the size of the left margin on your paper.

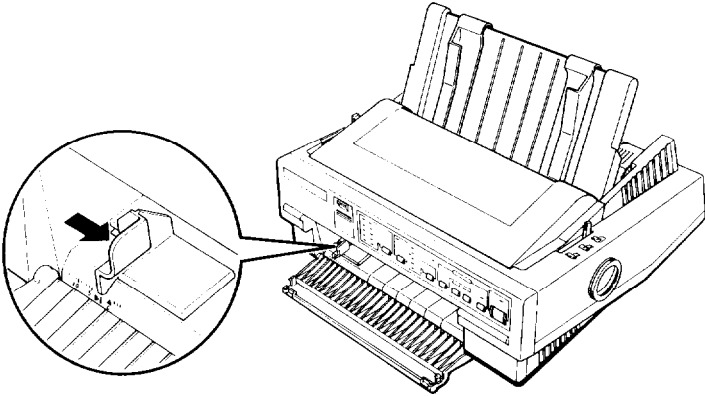

4. While aligning the paper's left edge with the edge guide, insert the paper firmly until it meets resistance; after a few seconds, the printer automatically loads the paper to the loading position.

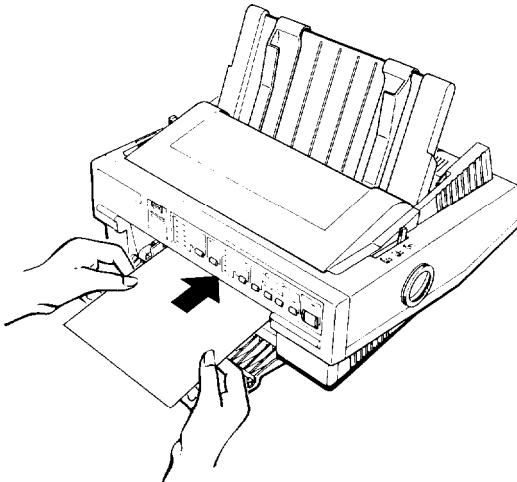



**CAUTION:** Use the knob on the right side of the printer only to clear paper jams when **the** printer is off. Otherwise, you may damage **the** printer or cause it to lose the top-of-form position.

If the platen turns but the printer doesn't load the paper, completely remove the paper and re-insert it more firmly.

To eject **the** paper, press **the** LOAD/EJECT button.

**Note:** The printer's built-in stacker in front of **the** paper guide can hold up to 50 sheets of ejected paper.

---

# Using Continuous Paper





You can print on continuous paper from **101 mm (4 inches)** to 254 mm (10 inches) wide on the ActionPrinter 5000 and from **101 mm (4 inches)** to **406 mm (16 inches)** wide on the ActionPrinter **5500**.

You can feed continuous paper from the rear, front, or bottom.

Your printer comes with the tractor installed in the push-tractor position, for feeding paper from the rear. If this is your paper-feeding method, skip to page 2-12. To feed paper from the front or bottom, you must install the tractor in the pull-tractor position. You can also install an optional pull tractor and use both the push and pull tractors together.

## Tractor position and available paper paths

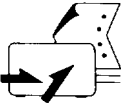
Below are the various ways of feeding continuous paper. Always move the paper-release lever to the position indicated for the paper-feeding method you are using.

Tractor position	Paper-release lever position	Paper-feeding method
Push-tractor position		
Pull-tractor position		

Make sure you align your paper supply with the paper loaded in the tractor so the paper feeds smoothly into the printer.

If you want to feed paper through the bottom paper slot, use a printer stand that has a large enough opening for paper to feed from the bottom without obstruction.

## Changing tractor positions

You can use the tractor unit as either a push tractor or a pull tractor. You should change the tractor position according to your paper feeding method. The printer comes with the tractor installed in the push-tractor position.

### Installing in the push-tractor position

1. Make sure the printer is turned off. Lift the printer cover and the paper guide up and off the printer.
2. If necessary, remove the tractor from the pull-tractor position by pressing the lock tabs open while lifting the tractor up and out of the mounting slots.
3. Press open the tractor's lock tabs. Hold the tractor horizontally above the printer and lower it straight down into the printer's back mounting slots.

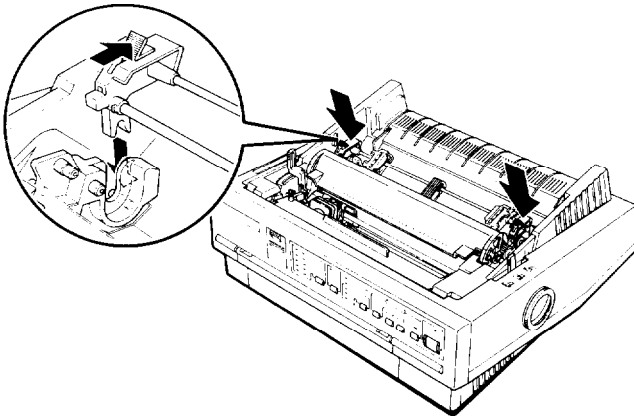

4. When the tractor is positioned in the mounting slots, release the lock tabs.
5. If you removed the clear plastic paper-tension unit previously, replace it by placing it on the printer's mounting pegs; then lower into place. Press on both ends of the paper-tension unit until you feel it click into place.

6. Replace the printer cover.
7. Move the paper-release lever to the push-tractor position.

You are now ready to load continuous paper with the push tractor.

### **Installing in the pull-tractor position**

1. Make sure the power is turned off. Lift the printer cover and paper guide up and off the printer.
2. Grasp both ends of the clear plastic paper-tension unit and lift it up from the front and lift it off the printer.
3. If necessary, remove the tractor from the push-tractor position by pressing the lock tabs open while lifting the tractor up and out of the mounting slots.
4. Press the tractor's lock tabs open. Tilt the tractor forward and lower it into the printer's front mounting slots. An arrow on each side of the mounting slots shows you where to align the tractor.

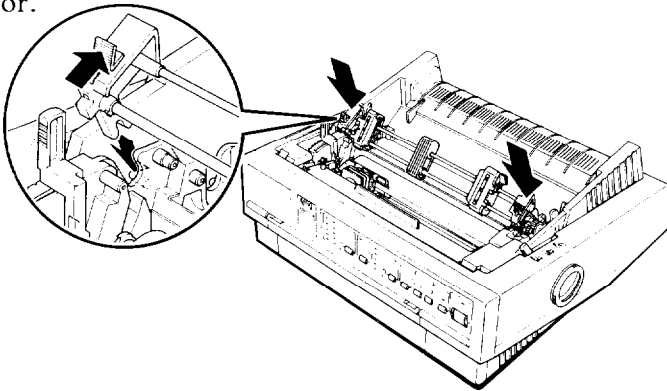

5. When the tractor is positioned in the mounting slots, release the lock tabs.
6. Pull the paper-release lever forward to the pull-tractor position.

You are now ready to load continuous paper.

### **Loading continuous paper with the push tractor**

1. Make sure the printer is turned off and the paper guide is removed.
2. Make sure the tractor is in the push-tractor position and the paper-release lever is in the push-tractor position.

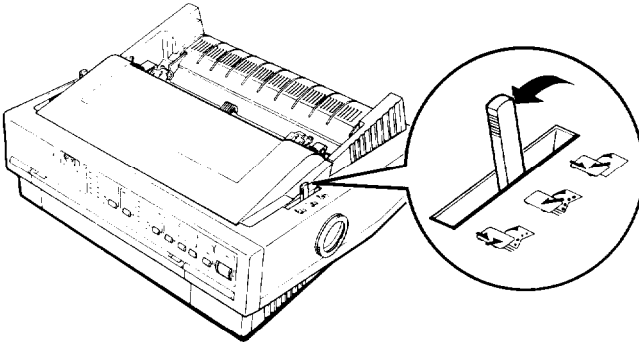

3. Release the tractor's sprocket units by pulling the sprocket lock levers forward.

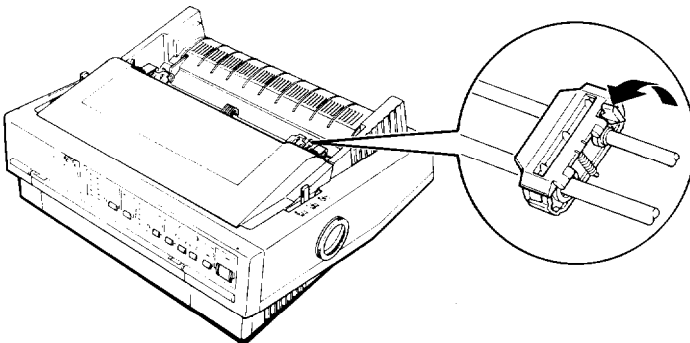

- Slide the left sprocket unit to approximately **12 mm** (1/2 inch) from the far left position and push the sprocket lock lever back to lock it in place. Then slide the right sprocket unit to match the width of your paper, but do not lock it. Move the paper support so it is midway between the sprocket units.

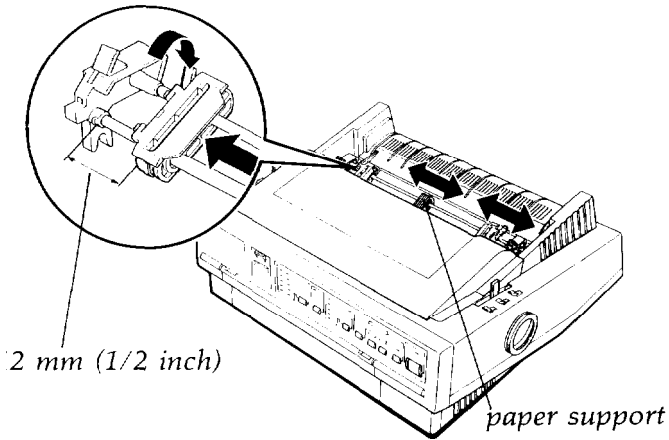

- Make sure your paper has a clean, straight leading edge. Then open the sprocket covers and fit the first four holes of the paper over the sprocket pins.

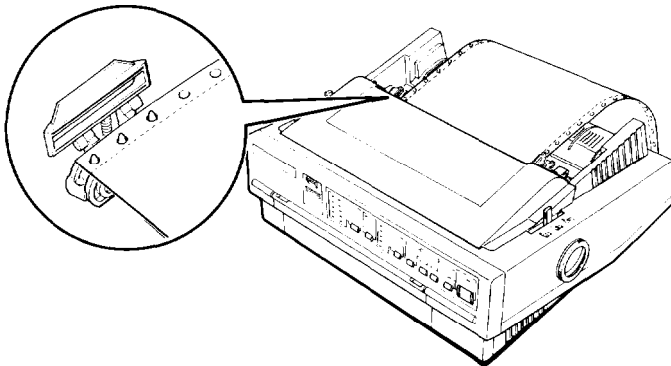



6. Close the sprocket covers.
7. Slide the right sprocket unit to remove any slack in the paper. Then lock it in place by pushing the sprocket lock lever back.
8. Place the notches on the paper guide straight down over the mounting posts on the printer.
9. Slightly lift the paper guide and then lower it until it rests on the printer.
10. Slide both edge guides to the middle of the paper guide.
11. Turn on the printer. The printer automatically advances the paper to the loading position when it receives data.

**Note:** You can also advance the paper to the loading position by pressing the **LOAD/EJECT** button.



**CAUTION:** Use the knob on the right side of the printer only to clear paper jams when the printer is off. Otherwise, you may damage the printer or cause it to lose the top-of-form position.

### Removing continuous paper from the push tractor

1. Press the **TEAR OFF** button to advance the paper to the tear-off position. (See Chapter 3 for more information.) Tear off any printed sheets.



**CAUTION:** Always tear off paper before back-feeding; back-feeding too many sheets can cause a paper jam.

2. Press the **LOAD/EJECT** button to feed the paper back to the standby position.
3. Remove the paper from the tractor unit.

## Loading continuous paper with the pull tractor

By placing the tractor in the pull-tractor position, you can load paper from the rear, front, or bottom. The steps are the same for all paper paths.

**Note:** When the tractor is in the pull-tractor position, do not use the **TEAR-OFF** button or the **LOAD/EJECT** button to feed the paper back to the standby position.

1. Make sure the printer is turned off and the paper guide and printer cover are removed.
2. Make sure the tractor is in the pull-tractor position and the paper-release lever is in the pull-tractor position.

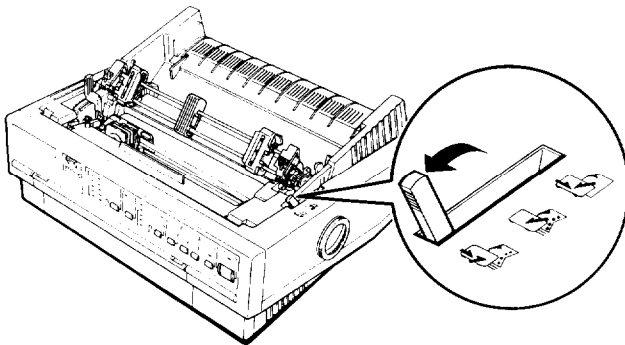

3. Release the tractor's sprocket units by pulling the sprocket lock levers forward.

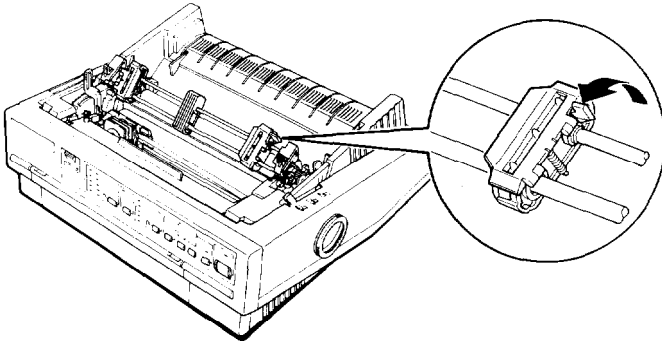

4. Slide the left sprocket unit to approximately 12 mm (1/2 inch) from the far left position and push the sprocket lock lever back to lock the sprocket unit in place. Then slide the right sprocket unit to match the width of your paper, but do not lock it in place. Move the paper support so it is midway between the sprocket units.

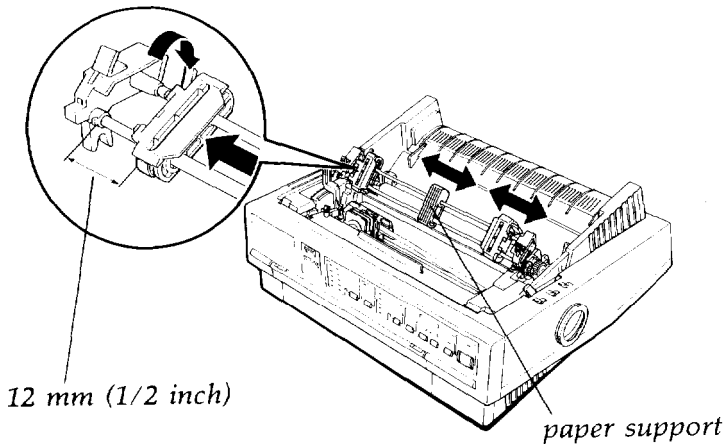

5. If you are inserting paper in the front paper slot, remove the front cover and slide the edge guide completely to the left.

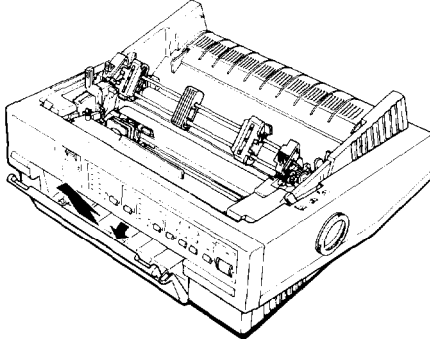

6. Make sure your paper has a clean, straight edge. Insert the paper into the desired paper slot (rear, front, or bottom) until it emerges between the platen and print head.
7. Pull the paper up until the perforation between the first and second pages is even with the top of the printer's ribbon.

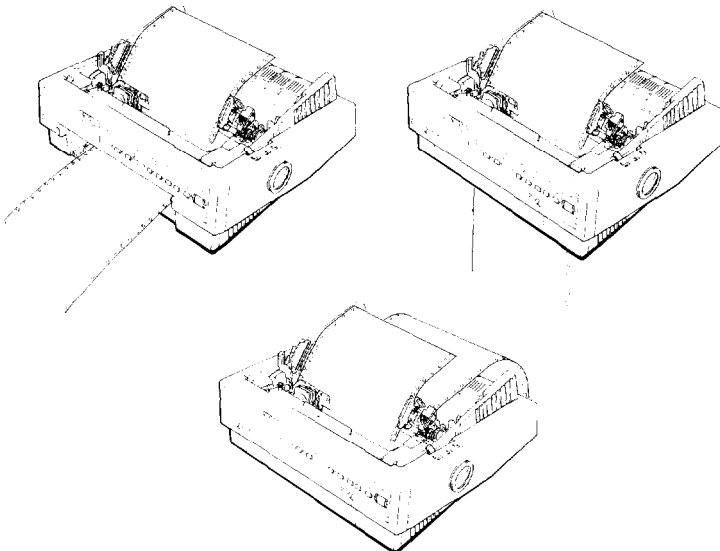

8. If you insert paper through the front paper slot, re-attach the front cover.
9. Fit the first four holes of the paper over the sprocket pins.

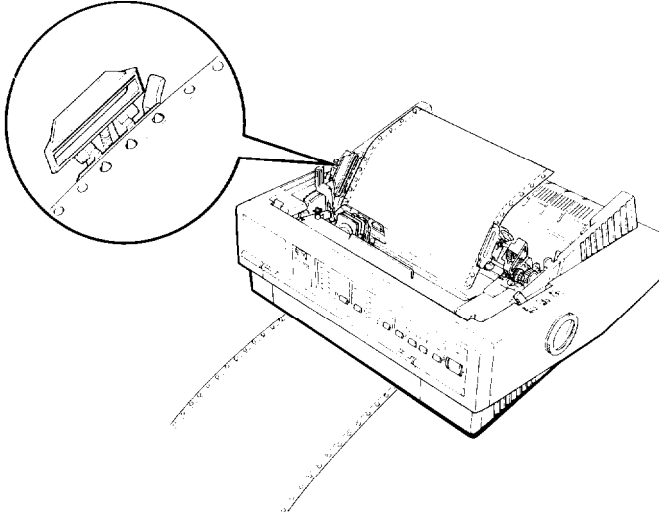

10. Close the sprocket covers.
11. Slide the right sprocket unit to remove any slack in the paper. Then lock it in place by pushing the sprocket lock lever back.
12. Place the notches on the paper guide straight down over the mounting posts on the printer.
13. Slightly lift the paper guide and then lower it until it rests on the printer.
14. Slide both edge guides to the middle of the paper guide.
15. Turn on the printer.

16. If necessary, adjust the paper position using the micro-feed feature described in Chapter 3.



**CAUTION:** Use the knob on the right side of the printer only to clear paper jams when the printer is off. Otherwise, you may damage the printer or cause it to lose the top-of-form position.

17. To replace the printer cover, insert the front tabs into the slots on the printer and then lower the cover into place.

### Removing continuous paper from the pull tractor

1. To remove continuous paper when using the pull tractor, tear off the paper at a point before it enters the paper slot.

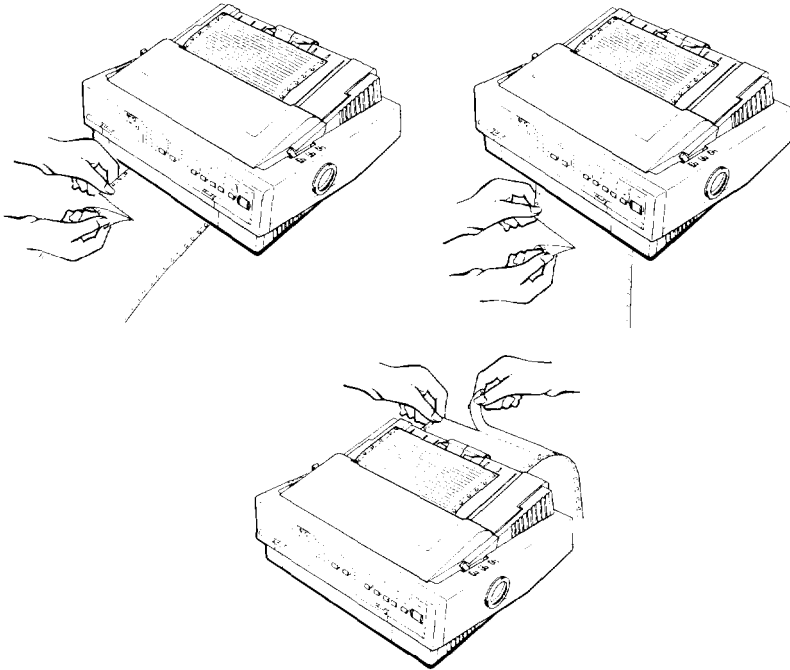

2. Press the LF/FF button to feed the remaining paper forward, out of the printer.

---

## Switching Between Continuous Paper and Single Sheets

When using the push tractor, you can easily switch to single-sheet printing without removing the continuous paper.

### Switching to single sheets

To switch from continuous paper to single sheets, follow the steps below.

1. If any printed sheets remain in the printer, press the **TEAR OFF** button to advance the paper to the tear-off position.
2. Tear off the printed pages.



#### CAUTION:

- Always tear off paper before back-feeding; back-feeding too many sheets can cause a paper jam.
- Never back-feed labels. Labels can easily come off their backing and **jam** the printer.

3. Press the **LOAD/EJECT** button. The printer feeds the continuous paper backward to the standby position. The paper is still attached to the push tractor but is no longer in the paper path.
4. Move the paper-release lever to the single-sheet position.

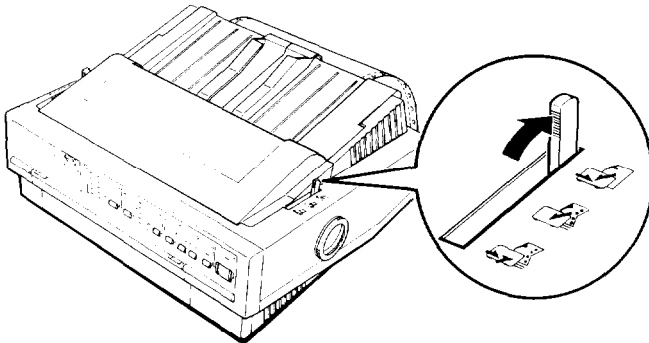



5. Lift the paper guide until it stops in the upright position.
6. Adjust the edge guides to match the width of your paper.

You can now load single sheets as described in Using Single Sheets in this chapter.

### **Switching to continuous paper**

To switch from single sheets back to continuous paper in the push tractor, follow the steps below.

1. If a single sheet is in the paper path, press the **LOAD/EJECT** button to eject it.
2. Slightly lift the paper guide and **then** lower it until it rests on the printer.
3. Slide both edge guides to the middle of the paper guide.
4. Move the paper-release lever to the push-tractor position.

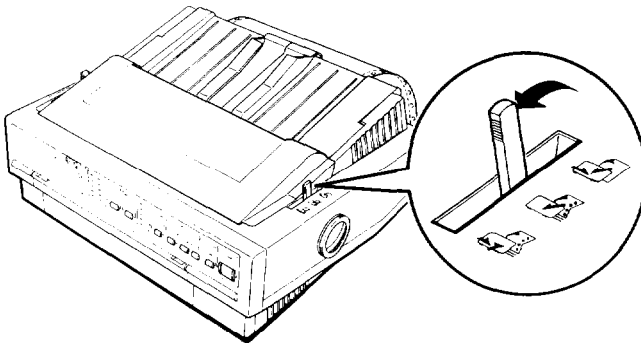

The printer automatically advances **the** continuous paper to the loading position when it receives data.

---

## Printing on Special Paper

In addition to printing on single sheets and continuous paper, your printer can print on a wide variety of other paper types, such as envelopes, labels, and multi-part forms. Before printing on special types of paper, you need to change the paper-thickness setting.



### CAUTION:

- When printing on labels or multi-part forms, make sure that your application program settings keep the printing entirely within the printable area.
- Always return the paper-thickness lever to position 0 when you return to printing on ordinary paper.

### Paper-thickness lever

Set the paper-thickness lever to match the thickness of your paper according to the table below.

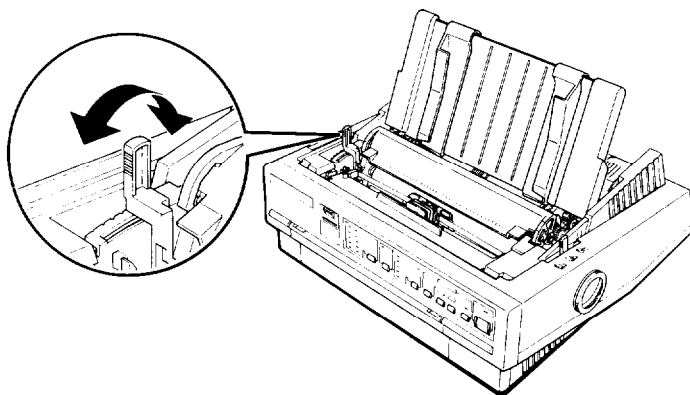

Paper Type	Lever Position
Ordinary paper (with film ribbon)	- 1
Thin paper	-1 or 0
Ordinary paper (single sheets or continuous)	0
Multi-part forms (carbonless) 2 sheets (original + 1 copy) 3 sheets (original + 2 copies) 4 sheets (original + 3 copies)	1 2 2 to 3
Labels	2
Envelopes	2 to 5

Note: Print speed is reduced for paper-thickness lever settings of 2 and above.

### Multi-part forms

Your printer can print on both single-sheet and continuous multi-part forms. You can load single-sheet multi-part forms only in the front paper slot.

You can use multi-part forms of up to four parts (including the original). Make sure you set the paper-thickness lever to the proper position. Use only carbonless multi-part forms.

You load multi-part forms the same way as you load single sheets or continuous paper. For best results with continuous multi-part forms, it is recommended you use the tractor installed in the push-tractor position together with the optional pull tractor.

For details, see Using Single Sheets or Loading continuous paper with the pull tractor earlier in this chapter. Pay special attention to setting the loading position as described in Using micro-feed in Chapter 3.

**CAUTION:**

- When printing multi-part forms, make sure the printing stays entirely within the printable area of **the** forms. (For more information on the printable area, see Chapter 7.)
- Use four-sheet thick multi-part forms only under normal operating conditions.
- Load single-sheet multi-part forms from the front only.

## Labels

When printing labels, always choose the type mounted on a continuous backing sheet with sprocket holes for use with a tractor. Do not try to print labels as single sheets because labels on a shiny backing sheet do not feed properly.

It is recommended you load labels from the front or bottom paper slots with the tractor in the pull-tractor position. You load labels the same way that you load continuous paper (with the pull tractor), except you set the paper-thickness lever to position 2.

See Loading continuous paper with the pull tractor earlier in this chapter for details.



**CAUTION:**

- Never feed labels backward with the **LOAD/EJECT** or **TEAR OFF** buttons. Labels can easily peel off **the** backing and jam the printer.
- Since labels are especially sensitive to temperature and humidity, use them only under normal operating conditions.
- Do not leave labels loaded in the printer between jobs; they curl around the platen and may jam when you resume printing.
- To remove labels from the paper path after you finish printing, first tear off the labels at a point before the paper slot. Then use the **LF/FF** button to advance the remaining labels out of the printer.

## **Envelopes**

You can load envelopes from the top just like single-sheet paper. However, you should pay attention to the special considerations below:

- Always set the paper-thickness lever to position 2, 3, or 4 depending on the thickness of the envelope.
- Always feed envelopes by inserting the wide edge into the printer.

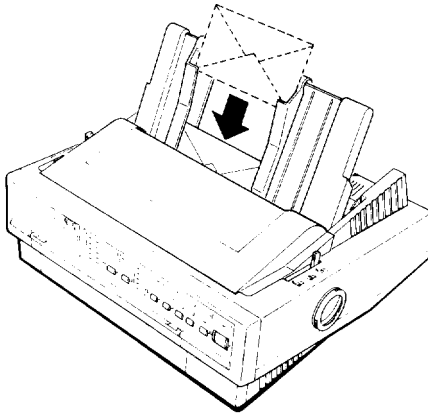

### **CAUTION:**

- Only use envelopes under normal operating conditions.
- Printing on the edge of an envelope can damage the print head. Make sure the printing stays entirely within the printable area of the envelopes. (See page 7-5.)

## Chapter 3

---

# Using the Printer

Control Panel .....	3-2
Lights .....	3-2
Buttons .....	3-3
Other control-panel features .....	3-5
DIP Switches .....	3-6
Changing a DIP-switch setting .....	3-6
DIP-switch tables .....	3-7
DIP-switch functions .....	3-9
Micro Feed .....	3-13
Using micro feed .....	3-13
Adjusting the loading position .....	3-14
Tear Off .....	3-16
Tear-off mode .....	3-16
Using the <b>TEAR OFF</b> button .....	3-17
Adjusting the tear-off position .....	3-18
Typestyles .....	3-19
Character fonts .....	3-19
Character spacing .....	3-23
Condensed printing .....	3-23
Data Dump Mode .....	3-24

---

## Control Panel

The indicator lights give you **the** current status of the printer. The buttons let you control **many** printer settings.

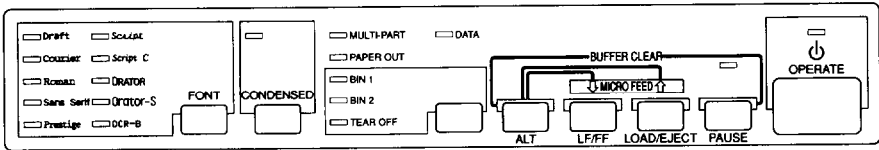

### Lights

#### OPERATE (green)

On when the operate switch is on and power is supplied.

#### PAUSE (orange)

On when **the** printer is not ready to print data. The **PAUSE** light is off unless you press the pause button to prevent printing.

#### DATA (orange)

**On** when the printer's buffer contains data.

#### MULTI-PART (green)

On when you **move** the paper-thickness lever to position 2 or higher. The printing speed is reduced **when** this light is on. When this light is blinking, you can use the micro-feed feature.

#### PAPER OUT (red)

On when **the** printer runs out of paper

#### BIN 1 (green)

On when bin 1 of the optional cut-sheet feeder is selected for paper feeding.

**BIN 2 (green)**

On when bin 2 of the optional cut-sheet feeder is selected for paper feeding.

**TEAR OFF (yellow)**

On when you press the **TEAR OFF** button to feed continuous paper to the tear-off position.

**CONDENSED (green)**

On when you select condensed printing from the control panel.

**Font (green)**

On when a specific font is selected.

**Buttons**

**PAUSE**

Press this button to temporarily stop printing. Press this button again to resume printing.

**LOAD/EJECT**

Press this button to load single-sheet or continuous paper to **the** loading position. However, the printer normally loads paper automatically. If single-sheet paper is already in the loading position, use this button to eject the sheet. If continuous paper is in **the** loading or tear-off position, press this button to feed it backward to **the** standby position.

**LF/FF (line feed/form feed)**

Tap this button briefly to feed the paper forward one line. Hold this button down to eject a single sheet of paper or advance continuous paper to the top of the next page. You can also use this button to load a single sheet of paper from the **cut-sheet** feeder or to feed continuous paper from the standby position to the loading position.



## ALT

Use this button in combination with other buttons to perform the following tasks:

<b>BUFFER CLEAR (PAUSE)</b>	Clears the printer's buffer and initializes the printer settings.
-----------------------------	---

Note: To clear the buffer but save the top-of-form setting: press the **PAUSE** button; then press the **LF/FF** button to advance the paper to the top of the next page; and then press the **ALT** and **PAUSE** buttons at the same time.

<b>MICRO FEED t (LOAD/EJECT)</b>	Feeds paper forward in 1/180-inch increments.
----------------------------------	---

↓ (LF/FF)	Reverse-feeds paper in 1/180-inch increments.
-----------	---

See Micro Feed later in this chapter for more information on the **MICRO FEED** button.

## Bin Select/TEAR OFF

This button selects the paper bin when both optional cut-sheet feeders are installed and you are printing on single sheets. When printing on continuous paper, press this button once to feed paper from the loading position to the tear-off position. Press this button again to feed the paper backward to the loading position.

## CONDENSED

Press this button to print condensed characters. Press it again to return to normal character printing.

## FONT

Press this button to select from among the built-in fonts.

Note: The panel's font name typesyles are meant as guides only; actual printed results **may** differ slightly.

## **Other control-panel features**

The control panel also gives you access to the two special functions below.

**Self test:** Hold down the **LF/FF** button (for LQ printing) or the **LOAD/EJECT** button (for draft printing) while turning on the printer to perform the self test. The self test lets you check that your printer is operating properly and gives you a printout of the current DIP-switch settings.

See the section on testing **the** printer in Chapter 1 for more information.

**Data dump:** Hold down the **LF/FF** and **LOAD/EJECT** buttons while turning on the printer to enter data dump mode. Data dump mode allows advanced users to find the cause of communication problems between the printer and **the** computer.

The data dump mode is more fully explained at the end of this chapter.

---

## DIP Switches

By setting the two printer's sets of DIP switches, you can control various printer features, such as the graphics character set and page length. New settings take effect whenever the printer is turned on. The DIP switches are located inside a compartment next to the control panel.

### Changing a DIP-switch setting

To change a DIP-switch setting, follow these steps:

1. Turn off the printer.
2. Open the DIP-switch cover.

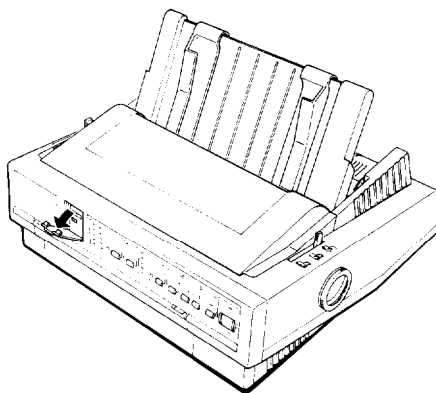

3. Use a pointed instrument, such as the tip of a pen, to turn a switch on or off. The section on DIP-switch functions lists the setting for each switch.
4. Close the DIP-switch cover.

The new DIP-switch settings take effect when you turn on the printer.

## DIP-switch tables

The tables below list the functions of the DIP switches. You can see the current DIP-switch settings at any time by running the self test as described in Chapter 1.

*Table 1 DIP switch 1*

SW	Description	On	Off
1-1	International character sets/ character tables	See Tables 3 and 4	
1-2			
1-3			
1-4			
1-5	Print direction	Unidirectional	Bidirectional*
1-6	High-speed draft	Off	On*
1-7	Input buffer	None	8 KB
1-8	1-inch skip-over-perforation	On	Off*

*Table 2 DIP switch 2*

SW	Description	On	Off
2-1	Page length (for continuous paper)	See Table 5	
2-2			
2-3	Tear off	On	Off*
2-4	Auto line feed	On	Off*

\* The asterisks indicate the default or factory settings. The defaults for DIP switches 1-1, 1-2, 1-3, 1-4, 2-1, and 2-2 vary according to the country.

Table 3 International character sets

Country	1-1	1-2	1-3	1-4
USA	On	On	On	Off
France	On	On	Off	Off
Germany	On	Off	On	Off
United Kingdom	On	Off	Off	Off
Denmark I	Off	On	On	Off
Sweden	Off	On	Off	Off
Italy	Off	Off	On	Off
Spain I	Off	Off	Off	Off

Table 4 Character tables

Character Table	1-1	1-2	1-3	1-4
Italic	Set the International character set according to Table 3.			Off
PC 437 (United States)	On	On	On	On
PC 850 (Multilingual)	On	On	Off	On
PC 860 (Portugal)	On	Off	On	On
PC 863 (Canada-French)	On	Off	Off	On
PC 865 (Norway)	Off	On	On	On

Table 5 Page length

Page length	2 - 1	2 - 2
8.5 inches (216 mm)	Off	On
11 inches (279 mm)	Off	Off
11.7 inches (296 mm)	On	On
12 inches (305 mm)	On	Off

## DIP-switch functions

This section describes the functions of the DIP switches.

### International character sets

You can choose from eight international character sets by setting DIP switches 1-1, 1-2, 1-3, and 1-4 according to DIP-switch Table 3. See the Appendix for character samples.

The character sets you can select by DIP switch are USA, France, Germany, United Kingdom, Denmark I, Sweden, Italy, and Spain I. However, you can also select the following sets only with the ESC R software command: Japan (English), Norway, Denmark II, Spain II, Latin America, Korea, and Legal.

**Note:** If you send the ESC t 0 command (to select italics) while DIP switch 1-4 is on, the international character set is always USA.

### Character tables

Your printer has six character tables built-in: five graphics character tables and one italics character table.

You can select the character tables with DIP switches **1-1**, **1-2**, **1-3**, and **1-4**, according to Table 4.

To select a graphics character table, you must first turn DIP switch **1-4** on.

**Note:** If you send the ESC t 1 command (to select graphics) while DIP switch 1-4 is off, the graphics character table is always PC 437 (United States).

All six character tables are included in the Appendix.

### **Print direction**

Printing is normally bidirectional. However, turning DIP switch 1-5 on for unidirectional printing—in which the print head prints in one direction only—allows for precise vertical printing alignment. This makes it ideal for printing graphics such as lines or boxes.

If DIP switch 1-5 is on, printing is unidirectional even if you select bidirectional with the ESC U 0 software command.

### **High-speed draft**

By setting DIP-switch 1-6 off, you can print draft characters at speeds up to 225 cps (characters per second). The printer reduces the number of dots in each draft-font character to increase the printing speed.

If you select emphasized printing or condensed printing during high-speed draft mode, printing speed temporarily switches to normal draft speed until the enhancement is turned off. Also, if a line contains superscript, subscript, dot-graphic, or downloaded characters, printing speed switches to normal draft speed for that line only.

### **Input buffer capacity**

The printer stores data sent from your computer in its input buffer. Keep DIP switch 1-7 off to select an 8KB buffer.

### **Skip-over-perforation**

Turning DIP switch 1-8 on when you are using continuous paper enables the skip-over-perforation function. **Use** this function to leave a 1-inch (25.4-mm) margin between the last printable line on one page and the first printable line on the next page. This causes the printer to skip over the perforation between continuous sheets.

Most application programs take care of the top and bottom margins. Do not turn on skip-over-perforation unless your program does not provide these margins.

Adjust your top-of-form position with the **MICRO FEED** buttons to get half of the margin at the bottom of one page and half at the top of the next page.

### **Continuous-paper page length**

When you are printing on continuous paper, DIP switches 2-1 and 2-2 let you select from the four page lengths described in DIP-switch Table 5.

### **Tear off**

You can turn on DIP switch 2-3 to select tear-off mode. See tear off later in this chapter for information on tear-off mode. Use the tear-off feature only with continuous paper loaded with the push tractor. Do not use the tear-off feature with the pull tractor.



**Auto line feed**

When auto line feed is on (DIP switch **2-4** on), the printer accompanies each carriage-return code (CR) received with a line-feed code (LF).

If your printer is double spacing, turn DIP switch **2-4** off. If each line overprints the next, turn DIP switch **2-4** on.

---

## Micro Feed

The micro-feed feature allows you to move the paper forward or backward in 1/180-inch increments. You can use this feature to adjust the loading and tear-off positions.

When you make adjustments to the loading or tear-off positions with continuous paper, the printer remembers the new position, even if you turn off the printer.

When you adjust the loading position of single-sheet paper, the printer remembers the new position until you turn off the power. The loading position returns to the factory setting when the power is turned on again.

### Using micro feed

To use the micro-feed feature, you press the **ALT** button at the same time as you press the **LOAD/EJECT** or **LF/FF** button, as indicated on the printer's control panel. To use the micro-feed feature, follow the steps below:

1. Make sure printing has stopped.
2. While holding down the **ALT** button, press the **LOAD/EJECT** button to feed the paper forward or the **LF/FF** button to feed the paper backward, as indicated by the arrows above the buttons.

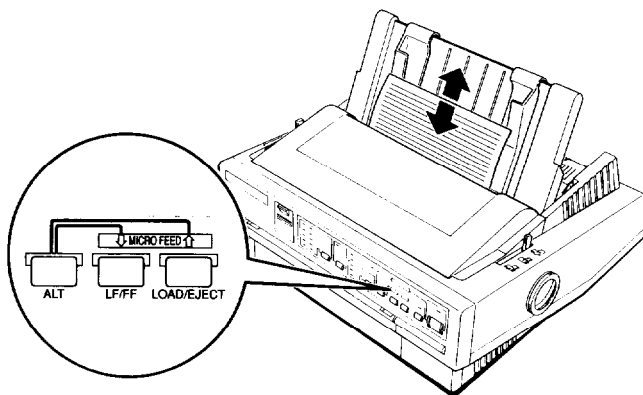

## Adjusting the loading position

The loading position is **the** position of **the** paper after it has been automatically loaded by the printer. If printing is too high or low on the page, change the loading position with the micro-feed feature as follows:

1. Make sure the printer is turned on.
2. Load either continuous or single-sheet paper. (Load continuous paper by pressing the **LOAD/EJECT** button.) The **MULTI-PART** light begins to blink.

**Note:** You can adjust the loading position only while the **MULTI-PART** light is blinking.

3. While holding down the **ALT** button, press the **LOAD/EJECT** button to adjust **the** loading position to a lower position on the page; press **the** **LF/FF** button to adjust the loading position to a higher position on **the** page. The **MULTI-PART** light stops blinking after a short time.

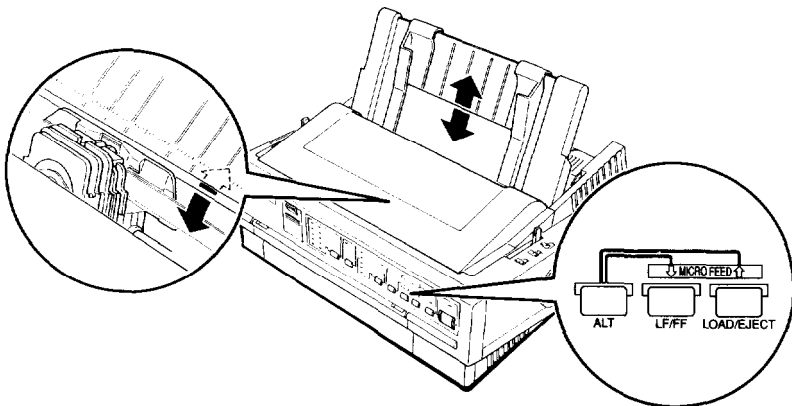

**Note:**

- For continuous paper, the printer remembers this new position **even** after it has been turned off and back on.
- The printer has a minimum and maximum loading position. If you try to advance the loading position beyond these limits, the printer beeps and **the** paper stops moving.
- **When** the paper reaches the factory-set loading position, the printer beeps and paper feeding pauses briefly. Use the factory setting as a reference point when adjusting the loading position.
- The printer remembers the new loading position for single-sheet paper only until you turn off the power. The loading position returns to the factory setting when the power is turned on again.

---

## Tear Off

After you **have** finished printing, you can use the tear-off feature to advance continuous paper **on the** push tractor to the tear-off edge of the printer. You can then easily tear off printed sheets. When you resume printing, the printer automatically feeds paper back to the loading position.

This feature lets you save paper that would normally be lost between documents.

You can use the tear-off feature in two ways: by turning on DIP switch **2-3** to select automatic tear-off mode, or by pressing the **TEAR OFF** button on the control panel.

If the perforation between pages is not aligned with the tear-off edge, you can adjust the tear-off position using the micro-feed feature.



### **CAUTION:**

- Never use the tear-off feature to reverse feed labels; they may come off their backing and jam the printer.
- Never reverse feed continuous paper when using the pull tractor; the paper could come off **the** pull tractor and jam the printer.

### **Tear-off mode**

When you select tear-off mode with DIP switch **2-3**, the printer automatically advances continuous paper to the tear-off position when you finish printing.

The printer advances paper to the tear-off position only when the printer receives a full page of data or **a** form-feed command and no more data is received for three seconds.

Enter tear-off mode by performing the following steps:

1. Make sure the printer is turned off.
2. Turn DIP switch 2-3 on.
3. Turn the printer on.

When tear-off mode is on and you print on continuous paper on the push tractor, the printer advances the final printed page to the tear-off position. Then you can tear off all printed pages.

If the perforation is not aligned with the tear-off edge, adjust the tear-off position as described in the section on adjusting the tear-off position later in this chapter.

When you resume printing, the printer automatically feeds the paper back to the loading position and begins printing. (You can also manually feed the paper back to the loading position by pressing the **LOAD/EJECT** or **TEAR OFF** button.)

### Using the **TEAR OFF** button

Whether or not the printer is in tear-off mode, you can use the **TEAR OFF** button to advance continuous paper to the tear-off position by following the steps below.

1. Make sure printing has finished. Then press the **TEAR OFF** button. The printer advances the paper to the tear-off edge and the **TEAR OFF** light comes on.
2. Tear off all printed pages. If the perforation is not aligned with the tear-off edge, adjust the tear-off position as described in the next section.
3. When you resume printing, the printer automatically feeds the paper back to the loading position and begins printing. (You can also manually feed the paper back to the loading position by pressing the **LOAD/EJECT** or **TEAR OFF** button.)

## Tear Off

### Adjusting the tear-off position

If the perforation is not aligned with the tear-off edge, adjust the tear-off position by following the steps below:

1. Make sure the paper is in the tear-off position and the **TEAR OFF** light is on.
2. While holding down the **ALT** button, press the **LOAD/EJECT** button to adjust the tear-off position to a lower position on the page or press the **LF/FF** button to adjust the tear-off position to a higher position on the page. The printer remembers the new tear-off position.
3. Tear off any printed pages.
4. When you begin printing, the printer automatically feeds the paper back to the loading position and begins printing. (You can also manually feed the paper back to the loading position by pressing the **LOAD/EJECT** or **TEAR OFF** button.)

Note:

- The printer has a minimum and maximum tear-off position. If you try to advance the loading position beyond these limits, the printer beeps and the paper stops moving.
- When the paper reaches the factory-set tear-off position, the printer beeps and paper feeding pauses briefly. Use the factory setting as a reference point when adjusting the tear-off position.

---

## Typestyles

You can produce a wide range of typestyles by combining different character fonts, widths, and other enhancements. You can select typestyles using the control panel, DIP switches, software commands, or your application program.

### Character fonts

Your printer has **10** built-in character fonts.

The draft font uses fewer dots per character for fast printing. This makes it ideal for rough drafts and editing work. (When you select the draft font, you can also use DIP switches to select an even faster high-speed draft mode. See DIP-switch functions in this chapter.)

All other fonts are letter quality (LQ) fonts. Letter quality fonts produce fully-formed characters for presentation-quality documents.

To select a font, press the **FONT** button on the printer's control panel until the light next to your desired font comes on. The font remains selected until you select another.

With Epson's new ESC/P 2 printer control language, the Roman and Sans Serif fonts are scalable. The minimum size of **each font is** 8 points and the maximum size is 32 points. You can increase the size of the font in 2-point increments.

Scalable fonts allow you to print in varying sizes with the appropriate software. The sample below shows characters of the following point sizes: 8, **10.5**, **16**, **22**, **24**, **28**, and **32**.

Roman

A A A A A A A

Sans serif

A A A A A A A



The following shows sample characters for each font:

**Draft (high-speed draft) \***

!"#\$%&'()\*+,-./0123456789:;<=>?@ABCDEFGHIJK  
LMNOPQRSTUVWXYZ[\]^\_`abcdefghijklmnopqrstuv  
wxyz{|}~ΔÇüéääääâçêëèìíîïÀĀĂĄÆǾðòûÿŮŮčŁŸŔŦáí

\* To select high-speed draft, turn DIP-switch **1-6** off.

**Draft (normal draft)**

!"#\$%&'()\*+,-./0123456789:;<=>?@ABCDEFGHIJK  
LMNOPQRSTUVWXYZ[\]^\_`abcdefghijklmnopqrstuv  
wxyz{|}~ΔÇüéääääâçêëèìíîïÀĀĂĄÆǾðòûÿŮŮčŁŸŔŦáí

**Epson Courier**

!"#\$%&'()\*+,-./0123456789:;<=>?@ABCDEFGHIJK  
LMNOPQRSTUVWXYZ[\]^\_`abcdefghijklmnopqrstuv  
wxyz{|}~ΔÇüéääääâçêëèìíîïÀĀĂĄÆǾðòûÿŮŮčŁŸŔŦáí

**Epson Roman**

!"#\$%&'()\*+,-./0123456789:;<=>?@ABCDEFGHIJK  
LMNOPQRSTUVWXYZ[\]^\_`abcdefghijklmnopqrstuv  
wxyz{|}~ΔÇüéääääâçêëèìíîïÀĀĂĄÆǾðòûÿŮŮčŁŸŔŦáí

## Epson Roman Proportional

!"#\$%&'()\*+,-./0123456789:;<=>?@ABCDEFGHIJK  
 LMNOPQRSTUVWXYZ[\]^\_`abcdefghijklmnopqrstuv  
 wxyz{|}~ΔçüéäääääçêëèèìîïÄÅĒæÆöôöûùÿÖÜç£¥Ptfaí

## Epson Sans Serif

!"#\$%&'()\*+,-./0123456789:;<=>?@ABCDEFGHIJK  
 LMNOPQRSTUVWXYZ[\]^\_`abcdefghijklmnopqrstuv  
 wxyz{|}~ΔçüéäääääçêëèèìîïÄÅĒæÆöôöûùÿÖÜç£¥Ptfaí

## Epson Sans Serif Proportional

!"#\$%&'()\*+,-./0123456789:;<=>?@ABCDEFGHIJK  
 LMNOPQRSTUVWXYZ[\]^\_`abcdefghijklmnopqrstuv  
 wxyz{|}~ΔçüéäääääçêëèèìîïÄÅĒæÆöôöûùÿÖÜç£¥Ptfaí

## Epson Prestige

!"#\$%&'()\*+,-./0123456789:;<=>?@ABCDEFGHIJK  
 LMNOPQRSTUVWXYZ[\]^\_`abcdefghijklmnopqrstuv  
 wxyz{|}~ΔçüéäääääçêëèèìîïÄÅĒæÆöôöûùÿÖÜç£¥Ptfaí

## Epson Script

!"#\$%&'()\*+,-./0123456789:;<=>?@ABCDEFGHIJK  
 LMNOPQRSTUVWXYZ[\]^\_`abcdefghijklmnopqrstuv  
 wxyz{|}~ΔçüéäääääçêëèèìîïÄÅĒæÆöôöûùÿÖÜç£¥Ptfaí

## Typstyles

### Epson Script C

!"#\$%&'()\*+,-./0123456789:;<=>?@ABCDEFGHIJK  
 LMNOPQRSTUVWXYZ[\]^\_`abcdefghijklmnopqrstuvwxyz  
 wx yz{|}~ΔÇüéâãäåçèéëïîïÏÄËæÆðöòûüÿÖÜøƒ¥¥Płfáí

### Epson Orator

!"#\$%&'()\*+,-./0123456789:;<=>?@ABCDEFGHIJK  
 .LMNOPQRSTUVWXYZ[\]^\_`ABCDEFGHIJKLMNOPQRSTU  
 WXYZ{|}~ΔÇÜÉÂÃÄÅÇÈÉÊËÏÎÏÄËÆæðöòûüÿÖÜøƒ¥¥Płfáí

### Epson Orator-S

!"#\$%&'()\*+,-./0123456789:;<=>?@ABCDEFGHIJK  
 LMNOPQRSTUVWXYZ[\]^\_`abcdefghijklmnopqrstu  
 vxyz{|}~ΔÇüéâãäåçèéëïîïÏÄËæÆðöòûüÿÖÜøƒ¥¥Płfáí

### OCR-B

!"#\$%&'()\*+,-./0123456789:;<=>?@ABCDEFGHIJK  
 LMNOPQRSTUVWXYZ[\]^\_`abcdefghijklmnopqrstu  
 vxyz{|}~ΔÇüéâãäåçèéëïîïÏÄËæÆðöòûüÿÖÜøƒ¥¥Płfáí

## Character spacing

Character spacings of 10, 12, or 15 cpi (characters per inch) and proportional are available using software commands or your application program. See Chapter 7 for the character spacings available for each font.

In the 10-, 12-, or 15-cpi modes, each character gets an equal amount of space. In proportional mode, the spacing varies from character to character. A narrow letter like a lowercase *i* receives less space than an uppercase *W*.

The printout below compares the different types of spacing:

This is 10 cpi printing.

This is 12 cpi printing.

This is 15 cpi printing.

This is proportional printing.

## Condensed printing

Condensed printing reduces the size of characters to approximately 60 percent of their normal width, allowing more characters to fit on a line. This is useful for spreadsheets and other applications where you need to print the maximum amount of information on a page.

You can condense 10 cpi, 12 cpi, and proportional spacing using software commands or your application program. You cannot condense 15-cpi printing.

The printout below shows condensed 10- and 12-cpi printing.

This is condensed 10 cpi printing.

This is condensed 12 cpi printing.

---

## Data Dump Mode

Data dump mode is a special feature that allows experienced users to find the cause of communication problems between the printer and computer. In data dump mode, the printer produces an exact printout of the codes it receives.

To use data dump mode, follow these steps:

1. Make sure paper is loaded and the printer is off.
2. Hold down both the **LF/FF** and **LOAD/EJECT** buttons while you turn on the printer.
3. Next, run either an application program or a program you have written in any programming language. Your printer prints all the codes it receives, as **shown** below.

Data Dump Mode

```
18 40 18 50 16 55 01 18 33 10 20 20 54 68 69 73 .e.P.U..3. This
20 20 69 73 20 61 6E 20 65 78 61 6D 70 6C 65 20 is an example
6F 66 20 61 20 64 61 74 61 20 64 75 6D 70 20 70 of a data dump p
72 69 6E 74 6F 75 74 2E 0D 0A 0A rintout....
```

4. To turn off data dump mode, press the **PAUSE** button to stop printing and then turn the printer off.

Look at the data dump shown in step 3. On the left side of the printout, all the codes are printed in hexadecimal format. On the right side of the printout, the same codes appear as printable characters or, if they are nonprintable codes—such as control codes—they appear as dots.

By looking at either the characters printed in the text field or the hex codes, you can see exactly what codes are being sent to the printer.

## Chapter 4

---

# Using Printer Options

Cut-Sheet Feeders .....	4-2
Installing a cut-sheet feeder .....	4-2
Loading paper with the single-bin cut-sheet feeder.. .....	4-3
Loading paper or envelopes with the high-capacity cut-sheet feeder .....	4-6
Assembling the double-bin cut-sheet feeder .....	4-9
Switching between continuous paper and the cut-sheet feeder .....	4-11
 Pull Tractor .....	 <b>4-12</b>
Loading paper with the push tractor and the optional pull tractor .....	4-12
 Interface Cards .....	 4-14
Installing an interface card .....	4-14
The C823051/C823061 serial interface card .....	4-16

---

## Cut-Sheet Feeders

Two cut-sheet feeders are available for use with your printer:

	Single-bin	High-capacity
ActionPrinter 5000	C80637*	C80638*
ActionPrinter 5500	C80639*	C80640*

\* Substitute for last digit, which varies by country.

The single-bin cut-sheet feeder holds up to 50 single sheets of paper and the high-capacity cut-sheet feeder holds up to 150 sheets of paper or up to **25** envelopes.

By connecting both cut-sheet feeders, you **can** operate them as a double-bin cut-sheet feeder (see Assembling the double-bin cut-sheet feeder). This allows you to load two different types of paper automatically.

Assemble the cut-sheet feeder by following the instructions in the manual that comes with it.

### Installing a cut-sheet feeder

You follow the same steps to install either the single-bin or high-capacity cut-sheet feeder:

1. Make sure the printer is turned off. Remove the paper guide and printer cover.
2. If the standard tractor is installed in the pull-tractor position, remove it and re-install in the push-tractor position. If **the** optional pull tractor is installed, remove it. In either case, make sure the paper-tension unit is installed.

---

#### Note:

- Store the paper guide and optional pull-tractor in a safe place; you will need them if you remove **the** cut-sheet feeder.
  - If you install **the** single-bin cut-sheet feeder, you need to re-install the paper guide after you load the paper.
-

3. Make sure the paper-release lever is in the single-sheet position.
4. Hold the cut-sheet feeder in both hands and press back on the latch levers on each side. Fit the notches in the cut-sheet feeder over the mounting posts on the printer. Release the latch levers and lower the cut-sheet feeder until it rests on the printer.

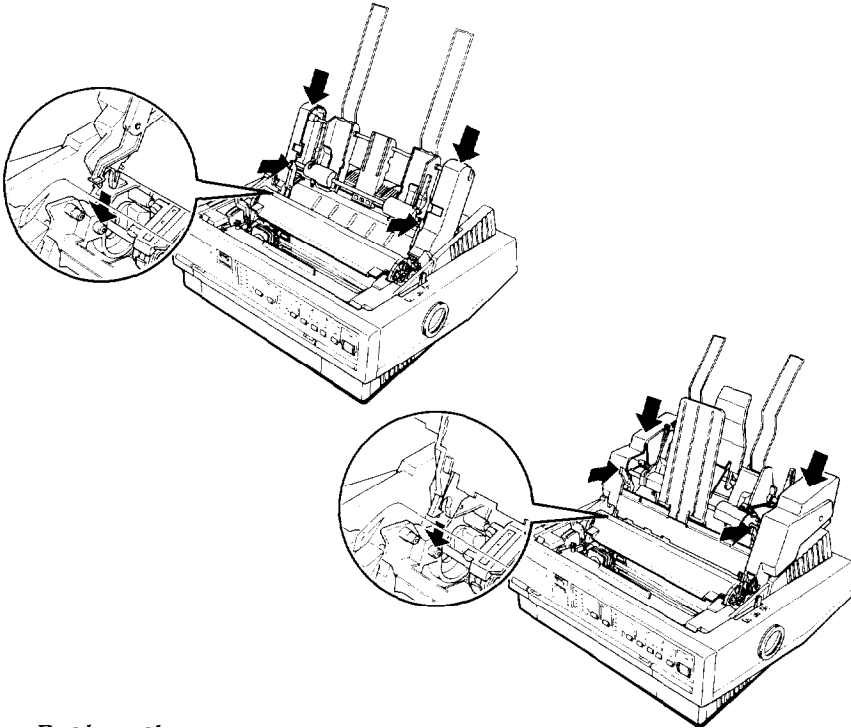

5. Replace the printer cover.

You are now ready to load paper with your cut-sheet feeder.

Removing a cut-sheet feeder is the reverse of the steps above.

### **Loading paper with the single-bin cut-sheet feeder**

Load paper using the single-bin cut-sheet feeder as follows:

1. Turn off the printer. Remove the paper guide, if necessary.



- Slide the left paper guide so it is aligned with the triangle mark. Next, slide the right paper guide to roughly match the width of your paper. Slide the paper support to midway between the paper guides.

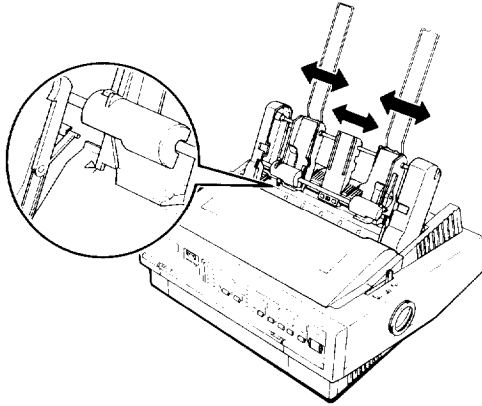

- Pull the paper-set levers all the way forward until the paper guides retract and lock open to allow for paper loading.

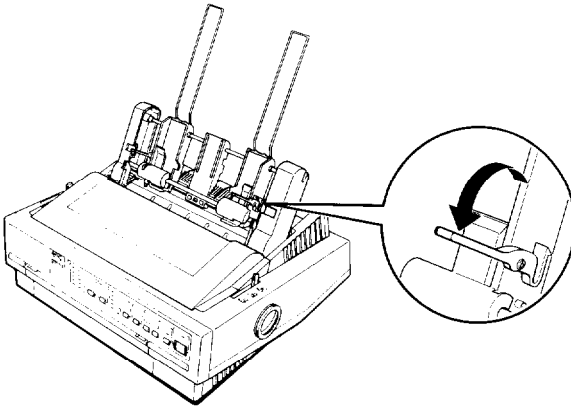

- Take a stack of paper and fan it. Next, tap the side and bottom of the paper on a flat surface to even up the stack.



**CAUTION:** Do not use multi-part forms, carbon paper, or labels in the cut-sheet feeder.

5. Insert up to **50** sheets of paper along **the** left paper guide.
6. Adjust **the** position of the right paper guide so that it **matches** your paper's width. Make sure the position of the guide allows the paper to move up and down freely.
7. Push the paper-set levers back to clamp the paper against the guide rollers.
8. If necessary, attach the stacker-support wires (that come with the cut-sheet feeder) to the edge guides of **the** paper guide.
9. Replace the paper guide by placing the notches on the paper guide straight down over the mounting posts on the printer. Lower the paper guide into position and then slide the edge guides to the middle.

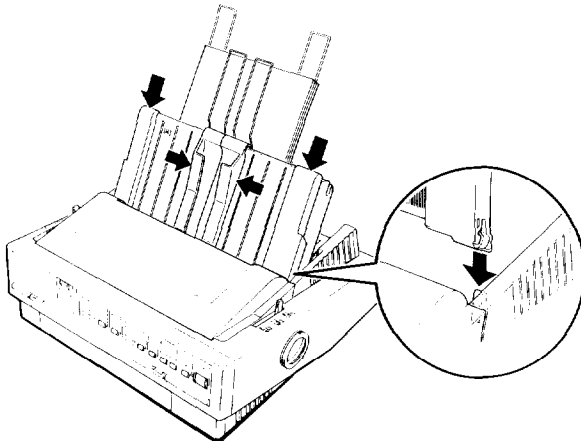

**Note:** When the cut-sheet feeder is installed, you can still load single sheets using the top paper guide or the front paper slot.

The cut-sheet feeder automatically loads paper when you send print data to **the** printer (as long as the **PAUSE** light is not on). You can also load paper from **the** cut-sheet feeder by pressing the **LOAD/EJECT** button.

## **Loading paper or envelopes with the high-capacity cut-sheet feeder**

To load paper using the high-capacity cut-sheet feeder follow these steps:

1. Pull the lock levers on the left and right paper guides forward.

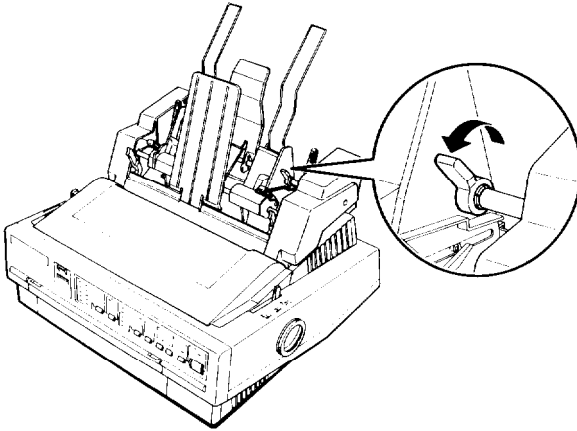

2. Slide the left paper guide until the ridge on the paper guide is aligned with the triangle mark on the front of the cut-sheet feeder; then lock the paper guide in place by pushing back on its lock lever. Next, slide the right paper guide to roughly match the width of your paper. Slide the paper support midway between the paper guides.

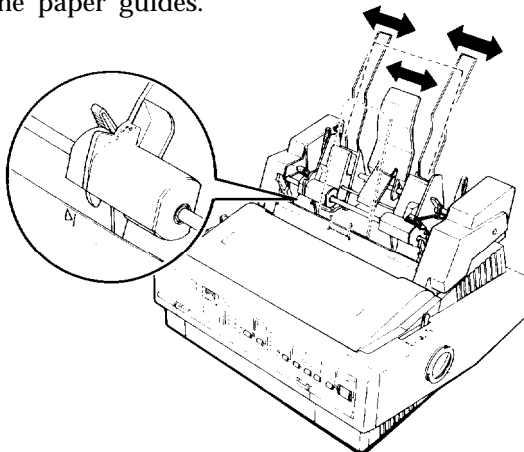

3. Pull the paper-set levers on each side of the cut-sheet feeder all the way forward until the paper guides retract and lock open to allow for paper loading.

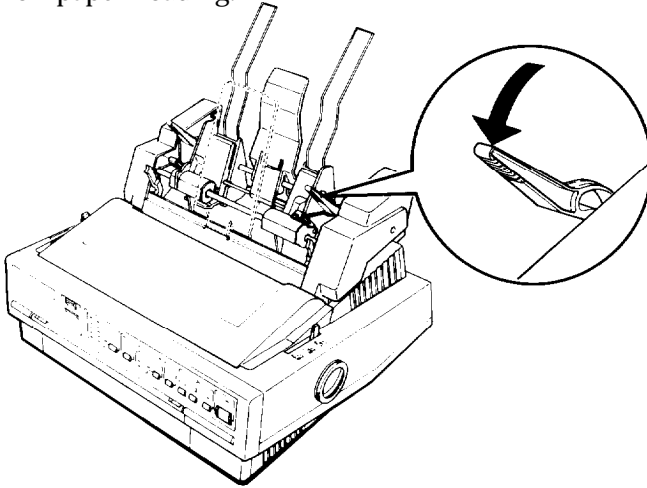

4. Take a stack of paper and fan it. Next, tap the side and bottom of the paper on a flat surface to even up the stack.



**CAUTION:** Do not use multi-part forms, carbon paper, or labels in the cut-sheet feeder.

5. Insert up to 150 sheets of paper or up to 30 air-mail or 25 plain bond envelopes.
6. Adjust the position of the right paper guide so that it matches your paper's width. Make sure that the position of the guide allows the paper to move freely up and down. Then lock the right paper guide in place by pushing back on the lock lever.

7. Set the envelope levers on each side of the cut-sheet feeder. Pull the levers forward for single sheets of paper or push them back for envelopes.

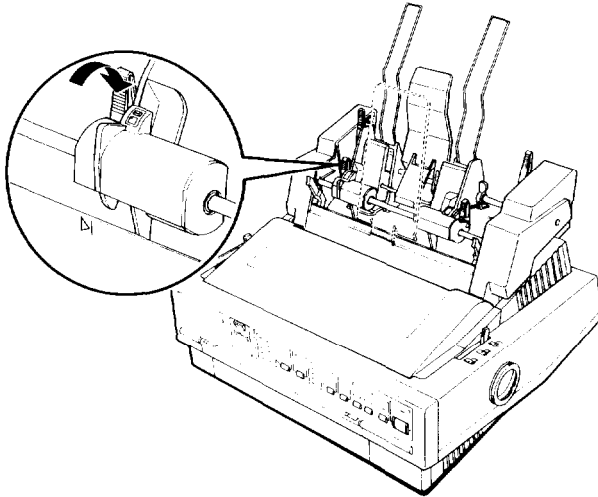

8. Push the paper-set levers back to clamp the paper or envelopes against the guide rollers.

Note: Even when the cut-sheet feeder is installed, you can also insert single sheets using the front paper slot or the slot between the paper guide and stacker.

The cut-sheet feeder automatically loads paper when you send print data to the printer (as long as the **PAUSE** light is not on). You can also load paper from the cut-sheet feeder by pressing the **LOAD/EJECT** button.

## Assembling the double-bin cut-sheet feeder

You can connect the single-bin cut-sheet feeder to the high-capacity cut-sheet feeder to create a double-bin cut-sheet feeder. Follow these steps:

1. Remove the gear cover from the back of the high-capacity cut-sheet feeder and store in a safe place.

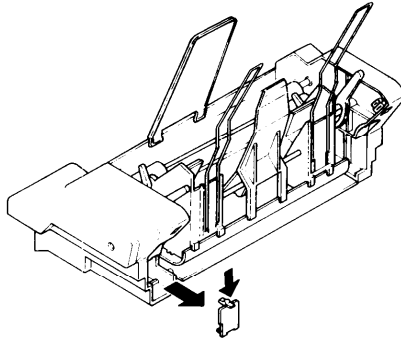

2. Hold the single-bin cut-sheet feeder in both hands. Fit the notches in the single-bin cut-sheet feeder over the mounting posts on the rear of the high-capacity cut-sheet feeder.

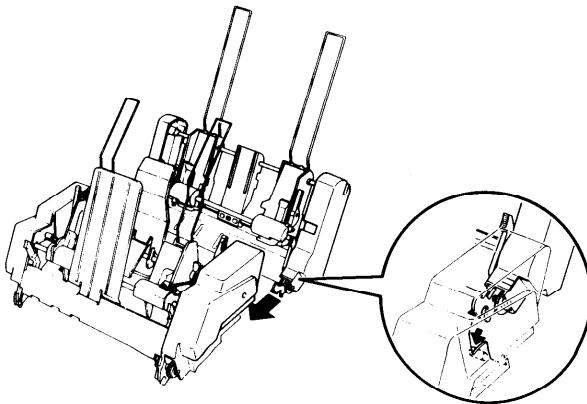

3. Pull the single-bin cut-sheet feeder toward the high-capacity cut-sheet feeder. While pushing firmly **on** the tab locks, press the two cut-sheet feeders together until they are securely locked together.

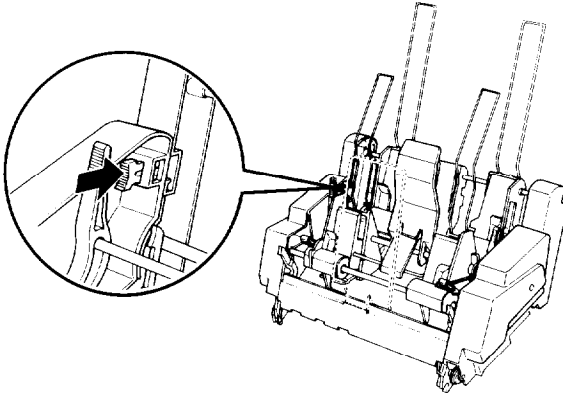

4. Install the assembled double-bin cut-sheet feeder on the printer. See the section on installing a cut-sheet feeder in this chapter.
5. Load paper into each bin. See the sections on loading paper in this chapter.

You can now use either cut-sheet feeder to load paper.

The high-capacity cut-sheet feeder becomes bin 1 and the single-bin cut-sheet feeder becomes bin 2. Select the bin number by pressing the Bin Select button. The light of the selected bin comes on.

You can also specify the bin number using software commands. You may be able to specify the bin number using your application software. See your application software manual for details.

## Switching between continuous paper and the cut-sheet feeder

You can easily switch between continuous paper and cut-sheet feeder operation without removing the continuous paper.

### Switching to continuous paper

1. If any single sheets are in the paper path, press the **LOAD/EJECT** button to eject them.
2. Move the paper-release lever to the push-tractor position.

**Note:** When you want to print several pages of continuous paper, fold the first printed page forward at the perforation after the perforation emerges from below the printer cover. This helps the printer feed the printed pages properly and prevents paper jams.

### Switching to the cut-sheet feeder

1. If any printed sheets remain in the printer, press the **TEAR OFF** button to advance the continuous paper to the tear-off position.
2. Tear off the printed pages.
3. Press the **LOAD/EJECT** button. The printer feeds the continuous paper backward to the standby position. The paper is still attached to the push tractor but is no longer in the paper path.



**CAUTION:** Never feed labels backward. Labels can easily come off their backing and jam the printer. Before you switch to the cut-sheet feeder when you are using labels, remove the labels from the printer as described on page 2-25.

4. Place the paper-release lever in the single-sheet position.



---

## Pull Tractor

The optional pull tractors, C80019\* (for ActionPrinter 5000) and C80022\* (for ActionPrinter 5500) provide optimum continuous paper handling. (The asterisk is a substitute for the last digit, which varies according to country.) The pull tractor is especially useful with continuous multi-part forms. For best results, use the optional pull tractor along with your standard tractor installed in the push-tractor position.

### Loading paper with the push tractor and the optional pull tractor

1. Make sure the printer is turned off, the standard tractor is installed in **the** push-tractor position, and **the** paper-release lever is in the push-tractor position.
2. Remove **the** printer cover, paper guide, and paper-tension unit by lifting them up and off the printer.
3. Install the optional pull tractor in the pull-tractor position as described in Chapter 2.

Note: The optional pull tractor cannot be installed in the push-tractor position.

4. Attach the continuous paper to the push tractor as described in Chapter 2.
5. Turn **on the** printer. Press **the** LOAD/EJECT button to load the paper, and then use **the** LF/FF button to feed two sheets of paper through the printer.



**CAUTION:** Use the knob on the right side of the printer only to clear paper jams **when the** printer is off. Otherwise, you may damage the printer or cause it to lose **the** top-of-form position.

6. Move the paper-release lever to the pull-tractor position.
7. Attach the continuous paper to the pull tractor as described in Chapter 2.
8. Pull out on the gear at the right side of the pull tractor and turn it to remove any slack in the paper between the push and pull tractors.

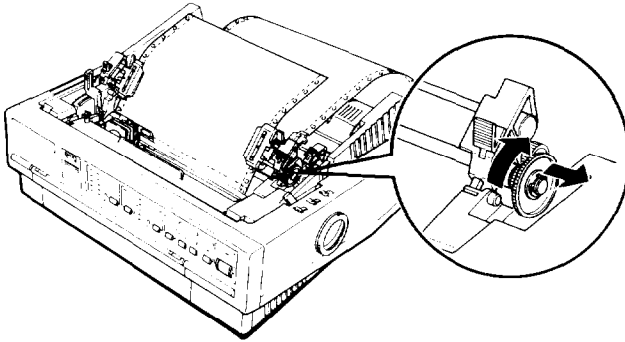

9. Place the notches on the paper guide straight down over the mounting posts on the printer.
10. Slide both edge guides to the middle of the paper guide. Slightly lift the paper guide and then lower it until it rests on the printer.
11. Replace the printer cover by inserting the front tabs into the slots on the printer and then lowering the cover into place.

Note: When you want to print several pages of continuous paper, fold the first page forward at the perforation after the perforation emerges from below the printer cover. This helps the printer feed the printed pages properly and prevents paper jams.

---

## Interface Cards

You can use optional interface cards to supplement your printer's built-in parallel interface.

The Epson interface cards below are compatible with your printer. (Not all interfaces are available in all countries.)

---

Model Number	Name
C823051/C823061	Serial interface card
C823071/C823081	32KB serial interface card
C82310*	32KB parallel interface card

---

\* Substitute for last digit, which varies by country.

If you are unsure whether you need an optional interface or would like to know more about interfaces, contact your dealer.

### Installing an interface card

Follow the steps below to install an optional interface card.

1. Make sure the printer is turned off. Unplug the printer's power cord and disconnect the interface cable.

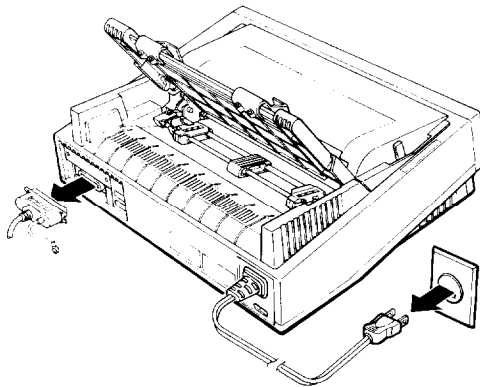

2. Remove the screws from the interface cover. Remove the interface cover.

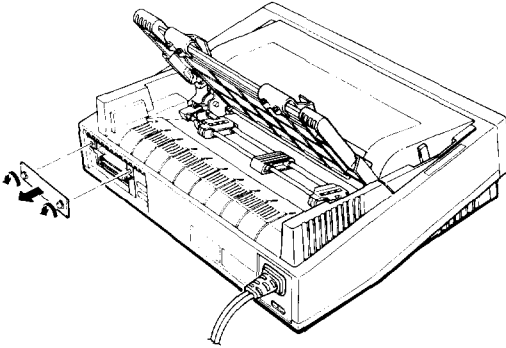

3. Be sure to set any switches and jumpers on the card. See **the** interface card's manual for details.
4. Slide the interface card along the slots on both sides of the interface compartment. Push in firmly to make sure you fully insert the connector at the rear of the interface card into the printer's internal socket.
5. Re-insert the screws and tighten to complete installation of the optional interface.

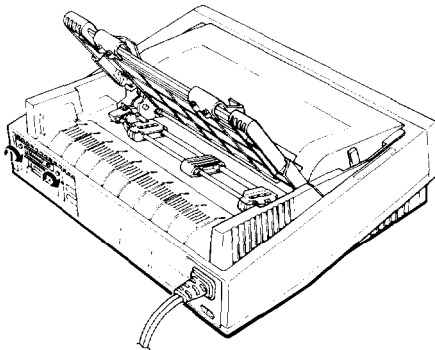

Removal of the interface card is the reverse of the steps above.

## ***Interface Cards***

### **The C823051/C823061 serial interface card**

To use the C823051/C823061 interface card, see the sections below on selecting a baud rate, handshake timing, and error handling. For all other data transfer conventions, such as word structure and communications protocol, see the C823051/C823061 interface card manual.

#### **Selecting a baud rate**

You can select from the following baud rates: 150, 300, 600, 1,200, **2,400, 4,800, 9,600**, and **19,200** bps (bits per second). When you set the baud rate, see the bit-rate selection table in the **C823051/C823061** interface card manual.

#### **Handshake timing**

When the vacant area for data in the input buffer drops to **256** bytes, the printer outputs an X-OFF code or sets the DTR flag to 1 (MARK) to indicate that it cannot receive data.

When the vacant area for data in the buffer increases to 528 bytes, the printer outputs an X-ON code or sets the DTR flag to 0 (SPACE) to indicate that it is ready to receive data.

#### **Error handling**

When the printer detects a parity error, it prints an asterisk (\*). The printer ignores all other errors, including framing and overrun errors.

## **Chapter 5**

---

# **Maintenance and Transportation**

Cleaning the Printer .....	5-2
Replacing the Ribbon Cartridge .....	5-3
Transporting the Printer .....	5-4

---

## Cleaning the Printer

To keep your printer operating at its best, you should clean it thoroughly several times a year.

1. Make sure the printer is turned off. Then remove any paper as well as the paper guide and tractor unit. Also remove the optional pull tractor and cut-sheet feeder or feeders, if installed.
2. Use a soft brush to carefully brush away all dust and dirt.
3. If the outer **case** or paper guide is dirty or dusty, clean it with a soft, clean, well-wrung cloth dampened with mild detergent dissolved in water. Keep the printer cover in place to prevent water from getting inside the printer.



### CAUTION:

- Never use alcohols or thinners to clean the printer; these chemicals can damage the components as well as the case.
- Do not use a hard or abrasive brush.
- Do not spray the inside of the printer with lubricants; unsuitable oils can damage the mechanism. Contact your dealer if lubrication is needed.



**WARNING:** Be careful not to get water on the printer mechanism or electronic components.

---

## Replacing the Ribbon

When the printing becomes too faint, you need to replace the ribbon cartridge. The following Epson ribbon cartridges are recommended:

	Standard fabric	Film
ActionPrinter 5000	# 7753	# 7768
ActionPrinter 5500	# 7754	# 7770

**To** replace the ribbon cartridge, follow the steps in Installing the ribbon cartridge in Chapter 1.

**Note:**

- Use the optional film ribbon cartridge when you want especially high quality printing. For everyday operations, use the standard ribbon cartridge.
- Do not use ribbon cartridge designed for nine-pin printers.



---

## Transporting the Printer

If you need to transport your printer some distance, carefully repack it using **the** original box and packing materials, as described below:

1. Turn off the printer.
2. Unplug the power cord from the electrical outlet; then disconnect the interface cable from the printer.
3. Remove the paper guide.
4. Remove the optional pull tractor and cut-sheet feeder or feeders, if installed.
5. Remove the ribbon cartridge.
6. Remove the paper-tension unit. Attach the protective locking clip to the paper-tension unit, and then replace the paper-tension unit. See page 1-5.
7. Make sure the standard tractor is installed in the push-tractor position.
8. Repack the printer, ribbon cartridge, paper guide, and power cord in the original packing materials and place them in the printer's original box.

## Chapter 6

---

# Troubleshooting

# 6

Problems and Solutions .....	6-2
Power Supply.....	6-3
Printing.....	6-4
Paper Handling .....	6-8
Options.....	6-10

---

## Problems and Solutions

This chapter describes problems you may encounter while operating your printer and provides their likely solutions. If you have a printer problem, find it in the list below and then see the appropriate page for the solution.

### Power supply

- Power is not being supplied. **See page 6-3.**

### Printing

- The printer does not print. **See page 6-4.**
- The print is faint or uneven. **See page 6-5.**
- Dots are missing in printed characters or graphics. **See page 6-5.**
- Printed characters are not what you expected. **See page 6-5.**
- The print position is not what you expected. **See page 6-6.**

### Paper handling

- Single sheets do not feed properly. **See page 6-8.**
- Continuous paper does not feed properly. **See page 6-9.**

### Options

- When using the cut-sheet feeder, the paper does not feed properly. **See page 6-10.**
- When using the optional pull tractor, the paper does not feed properly. **See page 6-11.**
- When using an optional interface, the printer does not operate properly. **See page 6-11.**

---

## Power Supply

### Power is not being supplied.

- **The OPERATE** light does not go on.

Check that the power cord is plugged into the electrical outlet properly.

If the electrical outlet is controlled by an outside switch or automatic timer, use a different outlet.

Plug another electrical device into the outlet to determine whether the outlet is operating properly.

- The **OPERATE** light comes on briefly and then goes off. The light stays off even when the power is switched on again.

Check that the printer's voltage rating matches the voltage of your electrical outlet. If the voltages do not match, unplug the printer and contact your dealer immediately. Do not reconnect the power cord to an electrical outlet.

---

## Printing

### The printer does not print.

- The **PAUSE** light is on.  
Press the **PAUSE** button.
- The **PAUSE** light is off but nothing is printed.  
Check that the software is installed properly for your printer. Check the software's printer settings.  
Check both ends of the interface cable between the printer and the computer. Make sure your interface cable meets both the printer and computer specifications. If you are using the built-in parallel interface, be sure your cable is a shielded twisted-pair parallel cable.
- The **PAPER OUT** light is on.  
Load paper in the printer.
- The printer sounds like it is printing, but nothing is printed.  
The ribbon cartridge may not be installed properly. See the section on ribbon installation in Chapter 1.  
The ribbon may be worn out. Replace the ribbon cartridge as described in Chapter 5.  
The paper thickness setting may be incorrect. See Setting the paper-thickness lever in Chapter 2.
- The printer makes a strange noise, the buzzer sounds several times, and the printer stops abruptly.  
Turn off the printer and check for a paper jam, a ribbon jam, or other problems. If the printer still does not print correctly, contact your dealer.
- The **PAUSE** light is flickering and the printer does not print, or it stops printing abruptly.  
The print head is overheated. Wait a few minutes; the printer resumes printing automatically when the print head cools.

**The print is faint or uneven.**

- Printed characters have parts missing at the bottom.

The **ribbon** cartridge may not be installed properly. See the section on ribbon installation in Chapter 1.

- The printout is faint.

The ribbon may be worn out. Replace the ribbon cartridge as described in Chapter 5.

Check that the paper-thickness lever is set correctly for the paper you are using. See Setting the paper-thickness lever in Chapter 2.

**Dots are missing in printed characters or graphics.**

- A line **of** dots is missing in the printout.

The print head is damaged. Stop printing and contact your dealer to have the print head replaced.

- Dots are missing in random positions.

Either there is too much slack in the ribbon or the ribbon has **come** loose. Reinstall **the** ribbon cartridge as described in Chapter 1.

**Printed characters are not what you expected.**

- The typestyles or characters that are set by your software cannot be printed.

Check **that** the software is correctly configured for your printer.

- The font selected on the control panel does not print.

Your software may be overriding your control panel setting. Check the font setting set in your software.

## Printing

- The wrong characters are printed.

The **wrong** character table or the wrong international character set is selected. Check the DIP-switch settings. See page 3-8.

- The characters printed are smaller than expected.

Press the **CONDENSED** button to cancel condensed mode. See page 3-4.

### The print position is not what you expected.

- Printing starts too high or too low on the page.

Adjust the top margin set by your application software or use micro feed to make minor adjustments to the loading position. See page **3-14**.

- All the text is printed on the same line.

Set DIP switch **2-4 on so that** the printer automatically adds a line-feed code to **each** carriage return.

- The text is printed with extra blank lines between the lines of text.

Two line-feed signals are being sent. Set DIP switch **2-4 off**.

Line spacing is incorrect. Adjust the line-space setting in your application software.

- Page length does not match the length of the paper.

Change **the** page-length setting with DIP switches 2-1 and **2-2**. See page **3-8**.

Check the page length set by your application software and adjust it if necessary.

- Regular gaps occur in the printout.  
One-inch skip-over-perforation may be set. Set DIP switch **1-8** off.
- Skip-over-perforation is set, but the perforation does not fall in the center of the skip.  
Make sure the page-length DIP-switch setting matches the page length of your paper. See page **3-7**.  
If your application program is setting the top and bottom margins, set DIP switch 1-8 off.
- Vertical printed lines do not align.  
Turn DIP switch 1-5 on for unidirectional printing.
- Printing starts too low on the *page*, or the bottom part of one page is printed at the top of the next page.  
Be sure to choose **the** correct printer when you choose a printer from your application program's menu. See page **1-14**.  
Use your application software to specify the type of paper you are using (single sheet or continuous).  
Use your application software to reduce or eliminate **the** top margin and to reduce the page length or lines per page setting.
- When clearing the buffer, you also lose the top-of-form.  
Always advance the paper to the top of the next page with the LF/FF button before clearing the buffer.

Note: You can check the operation of your printer using the self test. (See Running **the** self test in Chapter 1.) If **the** self test works properly, the printer is operating properly, and the problem probably lies in the computer, **the** software, or **the** cable. If the self test does not work, **contact** your dealer.



---

## Paper Handling

The following section guides you through problems in handling single sheets and continuous paper. If you are having problems using the optional cut sheet feeder, see the section on options starting on page **6-10**.

### Single sheets do not feed properly.

- When you insert the paper, the platen does not **rotate** and **paper** does not feed.

The paper may be too far to the right. Align the left edge guide with the arrow on the paper guide.

Check that the paper-release lever is in the single-sheet position.

- When you insert the paper, the platen rotates but paper does not *feed*.

Reinsert the paper more firmly.

- Paper feeding is crooked **or** the **paper jams**.

Turn off the printer and move the 'paper-release lever to the pull-tractor position. Pull out the paper and check the following two items:

Make sure the paper size is within the specified range. See page 7-4.

Make sure the paper is aligned with the edge guides.

- The **paper** does not fully eject.

Use the **LOAD/EJECT** button to eject paper. Do not use the **LF/FF** button.

The paper may be too long. Only use paper that is within the specified range. See page 7-4.

**Continuous paper does not feed properly.**

- When you send data, the platen does not rotate and the push tractor does not feed the paper.

The PAUSE light is on. Press the PAUSE button.

- When you send data or press the LOAD/EJECT button, the platen rotates, but the push tractor does not feed the paper.

The paper-release lever is in the wrong position. Move the paper-release lever to the push-tractor position.

The paper has come off the push tractor. Reattach the paper to the push tractor.

- Paper feeding *is* crooked or the paper jams.

Check that the paper-release lever is in the correct position.

Make sure the paper supply is not obstructed by a cable or some other object.

Make sure that your paper supply is positioned within 1 meter (3.28 feet) of the printer.

The position of your paper supply may be preventing it from feeding straight.

Check that the holes on the sides of the paper are aligned with each other. Also, make sure the sprocket units are locked and their covers are closed.

Check that the paper-thickness lever is set correctly for the paper you are using. See page 2-23.

Check that the paper size and thickness is within the specified range. See page 7-4.

- The paper does not eject properly.

The page is too long. Tear off the paper and remove it from the printer. Only use paper that is within the specified length range. See page 7-4.

---

## Options

### **When using the cut-sheet feeder, the paper does not feed properly.**

- When you send data, the platen does not rotate and paper does not feed.

The PAUSE light is on. Press the PAUSE button.

- When a print command is sent from the computer, the platen rotates but paper does not feed.

The cut-sheet feeder may be incorrectly installed. Remove the cut-sheet feeder and install it as described in Chapter 4.

Check that the paper-release lever is in the single-sheet position. See page 2-2.

The paper-set levers may be pulled forward. Push back on the paper-set levers.

Paper may be jammed near the print head.

There may be only one sheet left in the bin. Add more paper.

You may have loaded too many sheets in the cut-sheet feeder's bin. You can load up to 50 sheets in the single-bin cut-sheet feeder and up to 150 sheets or up to 30 air-mail or 25 plain bond envelopes in the high-capacity cut-sheet feeder.

- Two or more sheets feed at the same time.

You may have loaded too many sheets in the cut-sheet feeder's bin. See above.

You may have forgotten to fan the stack of paper before loading it into the bin. Remove the paper and fan it.

- Paper feeding is crooked.

The paper may be old or creased. Use only new, clean sheets of paper.

There may be too much paper in the stacker.

Make sure that your paper is the proper size and quality. See Chapter 7.

- One page of printing has spread to two pages.

Check the page-length setting in your software.

**When using the optional pull tractor, the paper does not feed properly.** (Check the section on continuous paper troubleshooting in this chapter.)

- Paper feeding is crooked or the paper jams.

The pull tractor and push tractor sprocket units may **not** be aligned correctly. Make sure the sprocket units on both tractors are aligned.

There may be slack in the paper. Adjust the position of the sprocket units to take up any slack across the width of the paper. Remove slack lengthwise by pulling out and rotating the gear on the right of the optional pull tractor.

**When using an optional interface, the printer does not operate properly.**

- The printer does not print or the printout is not what you expected.

You may be trying to use an interface card or cable with the wrong specifications. Check the specifications to make sure you can use the interface card or cable with this printer.

The computer and printer interface settings may not match. Make sure the settings on the computer and printer match.

The interface may have been disabled. Make sure that the switch near the interface connector is turned on.



## Chapter 7

---

# Technical Specifications

Printer Specifications .....	7-2
Printing.....	7-2
Paper .....	7-4
Mechanical .....	7-7
Electrical .....	7-8
Environmental .....	7-9
Interface Specifications .....	7-10
Specifications and pin assignments .....	7-10
Interface timing .....	7-13
Option Specifications.. .....	7-14
Cut-sheet feeders.....	7-14
Initialization .....	7-16
Default settings .....	7-16



---

## Printer Specifications

### Printing

*Printing method:* X-pin impact dot matrix

*Printing speed:*

Quality	Characters per inch	Characters/second/line
High-speed draft	10	225
Draft	10	210
	12	252
Letter Quality	10	70
	12	84

*Printing direction:* Bidirectional logic-seeking for text and graphics. Unidirectional for graphics. (Unidirectional **can** be selected by DIP switch or software command.)

*Line spacing:* 1/6 inch, 1/8 inch, or programmable in 1/360-inch increments

*Paper feed speed:* 77.6 milliseconds per 1/6-inch line; 2.2 inches per second with continuous feed

*Printable columns:*

Character sizes	Maximum printed characters	
	ActionPrinter 5000	ActionPrinter 5500
10 cpi	80	136
10 cpi condensed	137	164
12 cpi	96	204
12 cpi condensed	160	233
15 cpi		

**Buffer:** 0 KB or 8 KB (DIP-switch selectable)

**Character fonts:**

	15 cpi	10 cpi	12 cpi	Proportional
Epson Draft	<input type="radio"/>	<input type="radio"/>	<input type="radio"/>	
Epson Courier	<input type="radio"/>	<input type="radio"/>	<input type="radio"/>	
Epson Roman	<input type="radio"/>	<input type="radio"/>	<input type="radio"/>	<input type="radio"/>
Epson Sans Serif	<input type="radio"/>	<input type="radio"/>	<input type="radio"/>	<input type="radio"/>
Epson Prestige		<input type="radio"/>	<input type="radio"/>	
Epson Script		<input type="radio"/>	<input type="radio"/>	
Epson Script C				<input type="radio"/>
Epson Orator		<input type="radio"/>		
Epson Orator-S		<input type="radio"/>		
OCR-B		<input type="radio"/>		

You can also select other font/pitch combinations using ESC/P 2 commands. See the command summary in Chapter 8 for details.

**Scalable fonts:**

Font	Min pt	Max pt	Increments
Epson Roman	8	32	2 pt
Epson Sans Serif	8	32	2 pt

**Character tables:** One italic and five graphics character tables

**Character sets:** 14 international character sets and one legal character set



## Paper

### Single sheets:

Width	
top	148 to 257 mm (5.8 to 10.1 inches) for ActionPrinter 5000 148 to 420 mm (5.8 to 16.5 inches) for ActionPrinter 5500
front	182 to 257 mm (7.2 to 10.1 inches) for ActionPrinter 5000 182 to 364 mm (7.2 to 14.3 inches) for ActionPrinter 5500
Length	364 mm (14.3 inches) maximum
Thickness	0.065 to 0.14 mm (0.0025 to 0.0055 inches)
Weight	52.3 to 90 g/m <sup>2</sup> (14 to 24 lb)

### Single-sheet multi-part forms:

Width	182 to 216 mm (7.2 to 8.5 inches) for ActionPrinter 5000 182 to 364 mm (7.2 to 14.3 inches) for ActionPrinter 5500
Length	257 to 297 mm (10.1 to 11.7 inches)
Copies	Four sheets (one original plus up to three copies)
Thickness	0.12 to 0.32 mm (0.0047 to 0.012 inches)
Weight	40 to 58 g/m <sup>2</sup> (12 to 15 lb) per sheet

- Load single-sheet multi-part forms only into the front slot.
- Use only carbonless multi-part forms.

### Continuous paper:

Width	101 to 254 mm (4 to 10 inches) for ActionPrinter 5000 101 to 406 mm (4 to 16 inches) for ActionPrinter 5500
Copies	Four sheets (one original plus up to three copies)
Thickness	0.065 to 0.10 mm (0.0025 to 0.0039 inches) for one sheet 0.065 to 0.32 mm (0.0025 to 0.0012 inches) total
Weight	52.3 to 82 g/m <sup>2</sup> (14 to 22 lb) for one sheet 40 to 58 g/m <sup>2</sup> (12 to 15 lb) per sheet in multi-part forms

- Use only carbonless multi-part forms.

Note: You can use recycled paper with this printer; however, you may notice increases in ribbon consumption and paper jamming. If this occurs, use a higher grade of paper.

**Labels:**

Size	63.5 x 23.8 mm (2½ x 15/16 inches) 101 x 23.8 mm (4 x 15/16 inches) 101 x 27 mm (4 x 17/16 inches)
Thickness	0.07 to 0.09 mm (0.0028 to 0.0031 inches) for backing sheet 0.16 to 0.19 mm (0.0063 to 0.0075 inches) total

- Use continuous type labels only.
- Use labels only under normal temperature and humidity conditions.

**Envelopes :**

Size	No.6 — 166 x 92 mm (6.5 x 3.6 inches) No.10 — 240 x 104 mm (9.5 x 4.1 inches)
Thickness	0.16 to 0.52 mm (0.0063 to 0.0197 inches)
Weight	45 to 91 g/m <sup>2</sup> (12 to 15 lb)

- Use envelopes only under normal temperature and humidity conditions.
- Insert envelopes into the top slot only.

**Printable area:**

Single sheets

Printable area    A   B   B   C

- A The minimum top margin is 8.5 mm (0.33 inches).
- B The minimum left and right margins are 3 mm (0.12 inches).  
However, the maximum printable width is 203 mm (8 inches) for  
ActionPrinter 5000 or 345 mm (13.8 inches) for ActionPrinter 5500.
- C The minimum bottom margin is 13.5 mm (0.53 inches).

## Continuous paper

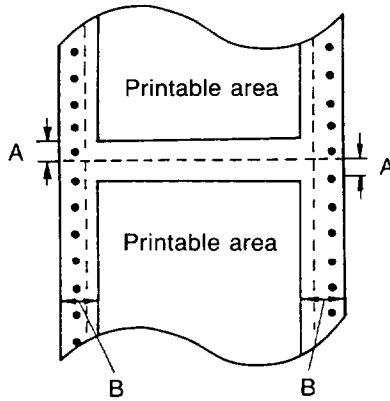

- A The minimum top and bottom margins (above and below the perforation) are 9 mm (0.35 inches).
- B The minimum left and right margins are 13 mm (0.51 inches). However, the maximum printable width is 203 mm (8 inches) for ActionPrinter 5000 or 345 mm (13.6 inches) for ActionPrinter 5500.

## Envelopes

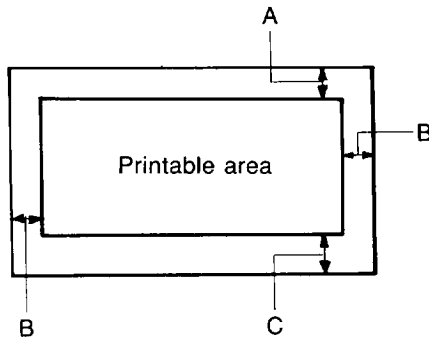

- A The minimum top margin is 8.5 mm (0.33 inches).
- B The minimum left and right margins are 3 mm (0.12 inches).
- C The minimum bottom margin is 13.5 mm (0.53 inches).

**Mechanical**

- Paper-feed methods:** Friction  
 Push tractor  
 Pull tractor  
 Single-bin cut-sheet feeder (optional)  
 High-capacity cut-sheet feeder (optional)  
 Double-bin cut-sheet feeder (by combining both optional cut-sheet feeders)
- Ribbon:** Black ribbon cartridge # 7753 (ActionPrinter 5000) or # 7754 (ActionPrinter 5500):  
 Life expectancy:  
 In LQ, at 48 dots/character: 2 million characters  
 In draft, at 28 dots/character: 3.42 million characters  
 Film ribbon cartridge # 7768 (ActionPrinter 5000) or # 7770 (ActionPrinter 5500) (optional):  
 Life expectancy (in LQ, at 48 dots/character): 0.2 million characters ( # 7768), 0.3 million characters ( # 7770)
- MCBF:** For all components (excluding print head):  
 3 million lines
- MTBF:** ActionPrinter 5000: 4000 power-on hours (25% duty)  
 ActionPrinter 5500:6000 power-on hours (25% duty)
- Print head life:** 200 million strokes per wire (with fabric ribbon)  
 100 million strokes per wire (with film ribbon)
- Dimensions and weight:**

	ActionPrinter 5000	ActionPrinter 5500
Height	151 mm (5.9 inches)	151 mm (5.9 inches)
Width	434 mm (17.1 inches)	609 mm (24.0 inches)
Depth	368 mm (14.5 inches)	368 mm (14.5 inches)
Weight	6.1 kg (13.4 lb)	8.4 kg (18.5 lb)

## Electrical

### 120 V model:

<b>Rated voltage:</b>	AC 120 V
<b>Input voltage range:</b>	AC 103.5 to 132 V
<b>Rated frequency:</b>	50 to 60 Hz
<b>Input frequency range:</b>	49.5 to 60.5 Hz
<b>Rated current:</b>	2.0 A
<b>Power consumption:</b>	(during self-test printing in draft mode at 10 cpi) ActionPrinter 5000: approx. 33 W ActionPrinter 5500: approx. 36 W
<b>Dielectric strength (Between AC line and chassis):</b>	AC 1.2 kV, 1 second

### 220/240 V model:

<b>Rated voltage:</b>	AC 220 to 240 V
<b>Input voltage range:</b>	AC 198 to 264 V
<b>Rated frequency:</b>	50 to 60 Hz
<b>Input frequency range:</b>	49.5 to 60.5 Hz
<b>Rated current:</b>	1.0 A
<b>Power consumption:</b>	(during self-test printing in draft mode at 10 cpi) ActionPrinter 5000: approx. 33W ActionPrinter 5500: approx. 36 W
<b>Dielectric strength (Between AC line and chassis):</b>	AC 1.5 kV, 1 second

**Note:** Check the label on the back of the printer for the voltage of your printer.

**Environmental**

**Temperature:**            Operation: 5° to 35°C (41° to 95°F)  
   Storage:    - 30° to 60°C ( -22° to 140°F)

**Humidity (without condensation):**  
   Operation: 10% to 80% RH  
   Storage:    5% to 85% RH

---

## Interface Specifications

Your printer is equipped with a parallel interface.

### Specifications and pin assignments

The built-in parallel interface has the following characteristics:

<i>Data format:</i>	B-bit parallel
<i>Synchronization:</i>	$\overline{\text{STROBE}}$ pulse
<i>Handshake timing:</i>	BUSY and $\overline{\text{ACKNLG}}$ signals
<i>Signal level:</i>	TTL compatible
<i>Connector:</i>	36-pin 57-30360 Amphenol connector or equivalent

The table below provides the connector pin assignments and describes their respective interface signals.

Signal Pin	Return Pin	Signal	Direction	Description
1	19	STROBE	IN	$\overline{\text{STROBE}}$ pulse to read data. Pulse width must be more than 0.5 microseconds at the receiving terminal.
2	20	DATA 1	IN	These signals represent Information of the 1st to 8th bits of parallel data respectively. Each signal is at HIGH level when data is logical 1 and LOW when it is logical 0.
3	21	DATA 2	IN	
4	22	DATA 3	IN	
5	23	DATA 4	IN	
6	24	DATA 5	IN	
7	25	DATA 6	IN	
8	26	DATA 7	IN	
9	27	DATA 8	IN	
10	28	ACKNLG	OUT	About an 11-microsecond pulse. LOW indicates that data has been received and that the printer is ready to accept more data.

## Interface Specifications

Signal Pin	Return Pin	Signal	Direction	Description
11	29	BUSY	OUT	A HIGH signal Indicates that the printer cannot receive data. The signal goes HIGH in the following cases: 1) During data entry (ea. char. time) 2) During printing 3) When the PAUSE button is pressed 4) During an error state.
12	30	PE	OUT	A HIGH signal indicates that the printer is out of paper.
13		SLCT	OUT	Pulled up to 5 V through 3.3 Kohm resistance.
14		$\overline{\text{AUTO FEED XT}}$	IN	When this signal is LOW, the paper is automatically fed one line after printing. (The signal level can be fixed to this by setting DIP switch 2-4 to on.)
15		NC		Not used.
16		GND		Logic ground level.
17		CHASSIS GND	IS -	Printer's chassis ground, which is isolated from the logic ground.
18		NC		Not used.
19-30	-	GND		Twisted-pair return signal ground level.
31	16	INIT	IN	When this level becomes LOW, the printer controller is reset to its power-up state and the print buffer is cleared. This level is normally HIGH; its pulse width must be more than 50 microseconds at the receiving terminal.
32		$\overline{\text{ERROR}}$	OUT	This level becomes LOW when the printer is: 1) in a paper-out state 2) when the PAUSE button is pressed 3) in an error state.



Signal Pin	Return Pin	Signal	Direction	Description
33	—	GND	—	Same as for pins 19-30.
34	—	NC	—	Not used.
35	—	—	O U T	Pulled up to 5 V through 3.3 Kohm
36	—	$\overline{\text{SLCT IN}}$	I N	The DC1/DC3 code is valid only when this signal is HIGH. This signal is always LOW.

**Note:**

- The column heading “Direction” refers to the direction of signal flow as viewed from the printer.
- “Return” denotes the twisted-pair return, to be connected at signal ground level. For the interface wiring, be sure to use a twisted-pair cable for each signal and to complete the connection on the return side.
- All interface conditions are based on the TTL level. Both the rise and fall times of each signal must be less than 0.2 microseconds.
- Data transfer must be carried out by observing the  $\overline{\text{ACKNLG}}$  or BUSY signal. (Data transfer to this printer can be carried out only after receipt of the  $\overline{\text{ACKNLG}}$  signal or when the BUSY signal is LOW.)

### Interface timing

The figure below shows the timing for the parallel interface.

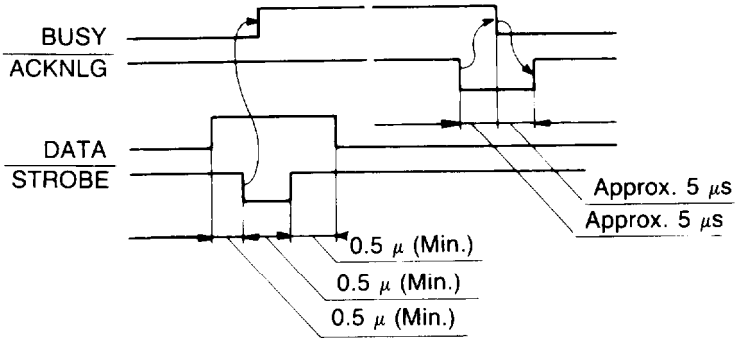

---

## Option Specifications

### Cut-sheet feeders

\* The asterisk is a substitute for the last digit, which varies according to country.

### Dimensions and weight

Printer	Cut-sheet feeder	Height	Width	Depth	Weight
Action-Printer 5000	Single-bin C80637*	377 mm (14.8 inches)	434 mm (17.1 inches)	444 mm (17.5 inches)	0.55 kg (1.21 lb)
	High-capacity C80638*	367 mm (14.4 inches)	434 mm (17.1 inches)	434 mm (17.1 inches)	1.55 kg (3.42 lb)
Action-Printer 5500	Single-bin C80639*	377 mm (14.8 inches)	609 mm (24.0 inches)	444 mm (17.5 inches)	0.75 kg (1.65 lb)
	High-capacity C80640*	367 mm (14.4 inches)	609 mm (24.0 inches)	434 mm (17.1 inches)	2.15 kg (4.74 lb)

Dimensions when mounted on the printer; includes printer dimensions

### Bin capacity

Single sheets: C80637\* and C80639\*

Up to 50 sheets of 82-g/m<sup>2</sup> (22-lb) paper

C80638\* and C80640\*

Up to 150 sheets of 82-g/m<sup>2</sup> (22-lb) paper

Envelopes: C80638\* and C80640\*

Up to 25 (plain bond)

Up to 30 (air mail)

**MCBF:** 100,000 cycles

**Paper:**

		Single sheets	Envelopes (C80638* only)
Width	C80637*	182 to 216 mm (7.17 to 8.50 inches)	N/A
	C80638*	182 to 216 mm (7.17 to 8.50 inches)	165 to 241 mm (6.50 to 9.49 inches)
	C80639*	182 to 420 mm (7.17 to 16.54 inches)	N/A
	C80640*	182 to 420 mm (7.17 to 16.54 inches)	165 to 241 mm (6.50 to 9.49 inches)
Length		210 to 305 mm (8.27 to 12.00 inches)	92 to 104 mm (3.62 to 4.09 inches)
Thickness		0.07 to 0.10 mm (0.0028 to 0.0039 inches)	0.16 to 0.52 mm (0.0063 to 0.0205 inches)
Weight		64 to 82 g/m <sup>2</sup> (17 to 22 lbs)	45 to 91 g/m <sup>2</sup> (12 to 24 lbs)

**Paper storage conditions**

Temperature: 18° to 22°C (64° to 72°F)

Humidity: 40% to 60%

**Environmental**

**Temperature:** Operation: 5° to 35°C (41° to 95°F)  
Storage: - 30° to 60°C (-22° to 140°F)

**Humidity (without condensation):** Operation: 15% to 80% RH  
Storage: 5% to 90% RH

**Note:**

- 90-g/m<sup>2</sup> (24-lb) paper printing is available only under normal environmental conditions.
- Envelope printing is available only with the C80638\* and C80640\* cut-sheet feeders, under normal environmental conditions.

---

## Initialization

The printer can be initialized (returned to a fixed set of conditions) in three ways:

---

Hardware initialization	<ul style="list-style-type: none"><li>• The power is turned on.</li><li>• The printer receives an INIT signal from the parallel interface (pin 31 goes LOW).</li></ul>
Software initialization	<ul style="list-style-type: none"><li>• Software sends the ESC @ command.</li></ul>
Control panel initialization	<ul style="list-style-type: none"><li>• You press the PAUSE and ALT buttons at the same time (buffer clear).</li></ul>

---

## Default settings

The table below shows the default conditions that take effect when the printer is initialized.

---

Item	Default condition
Top of form position	Current paper position
Page length	The current DIP-switch setting
Left and right margins	Cancelled
Line spacing	1/6 inch
Character pitch	10 cpi or condensed (depending on control panel selection)
Vertical tab position	Cleared
Horizontal tab positions	Every eight characters
Font selection	Last font selected on control panel
Special printing effects	Cancelled (except condensed printing)
User-defined character set	Hardware: cleared Software/control panel: deselected only

---

In addition, hardware and control panel initialization erase any text in the data buffer of all text.

# Chapter 8

---

## Command Summary

Using the Command Summary .....	8-2
Commands Arranged by Topic .....	8-3
General operation .....	8-3
Paper feeding .....	8-3
Page format .....	8-4
Print position motion .....	8-5
Font selection., .....	8-6
Font enhancement .....	8-7
Spacing .....	8-9
Character handling., .....	8-9
Bit image. ....	8-11
Graphics .....	8-12



---

## Using the Command Summary

This printer uses the Epson ESC/P 2 printer control language. You can use these commands to produce high quality, laser-like printouts. ESC/P 2 commands provide scalable fonts (Epson Roman and Epson Sans Serif) and enhanced graphics.

The following section lists and describes all the commands by topic. If a command has no parameters, it is merely listed. If it has parameters, they are explained. The parameters are indicated by lowercase italicized letters, usually *n*. The examples below show how the parameters are indicated.

ESC @ is a command with no parameters.

ESC U 1/0 is a command that uses 1 to turn the feature on and 0 to turn it off.

ESC \$ *n*<sub>1</sub> *n*<sub>2</sub> is a command with two parameters.

ESC D *nn* is a command with a variable number of parameters.

---

---

## Commands Arranged by Topic

### General operation

ASCII	Dec.	Hex.	Description
ESC @	64	40	Initialize Printer
ESC U 1/0	85	55	Turn Unidirectional Mode On/Off
ESC EM n	25	19	Control Paper Loading/Ejecting n = "1" Select bin 1 of CSF n = "2" Select bin 2 of CSF n = "R" Eject a sheet

- For the ESC EM command the variables are the characters "1" (49 decimal or 31 hex) and "2" (50 decimal or 32 hex). Do not use 1 decimal, 01 hex, 2 decimal, or 02 hex.

### Paper feeding

ASCII	Dec.	Hex.	Description
<b>CR</b>	13	0D	Carriage Return
FF	12	0C	Form Feed
LF	10	0A	Line Feed
ESC 0	48	30	Select 1/8-inch Line Spacing
ESC 2	50	32	Select 1/4-inch Line Spacing
ESC 3 n	51	33	Set n/180-inch Line Spacing
ESC + n	43	2B	Set n/360-inch Line Spacing



**Page format**

ASCII	Dec.	Hex.	Description
<b>ESC ( c m n</b>	40 99	28 63	<b>Set Page Format</b> <b>ESC ( c 4 0 m1 m2 n1 n2</b> $m = m1 + m2 \times 256$ <b>m: Top margin in defined units</b> $n = n1 + n2 \times 256$ <b>n: Bottom margin in defined units</b>
ESC ( C m n	40 67	28 43	<b>Set Page Length in Defined Units</b> <b>ESC ( C 2 0 n1 n2</b> $n = n1 + n2 \times 256$ <b>n: Number of defined units</b>
ESC C n	67	3	<b>Set Page Length in Lines</b> <b>n = number of lines (1-127)</b>
ESC C 0 n	67	43	<b>Set Page Length in Inches</b> <b>n = number of inches (1-22)</b>
ESC N n	78	4E	<b>Set Bottom Margin for Continuous Paper</b> <b>n = number of lines (1-127)</b>
ESC O	79	4F	<b>Cancel Top/Bottom Margin for Continuous Paper</b>
<b>ESC 1 n</b>	108	6C	<b>Set Left Margin</b> <b>n = left margin column</b>
ESC Q n	81	51	<b>Set Right Margin</b> <b>n = right margin column</b>

## Print position motion

ASCII	Dec.	Hex.	Description
ESC \$ n1 n2	36	24	Set Absolute Horizontal Print Position $n = n1 + n2 \times 256$ <i>n</i> : Specifies print position from left margin in defined units <ul style="list-style-type: none"> <li>The default unit is 1/60 inch.</li> </ul>
ESC \ n1 n2 92		5C	Set Relative Horizontal Print Position $n = n1 + n2 \times 256$ <i>n</i> : Moves current print position in defined units <ul style="list-style-type: none"> <li>The default unit is 1/120 inch in draft mode and 1/180 inch in LQ mode.</li> </ul>
ESC ( V nn 40 86	28 56		Set Absolute Vertical Print Position ESC ( V 2 0 n1 n2 $n = n1 + n2 \times 256$ <i>n</i> : Specifies print position from top margin in defined units
ESC ( v nn 40 118	28 76		Set Relative Vertical Print Position ESC ( v 2 0 n1 n2 $n = n1 + n2 \times 256$ <i>n</i> : Moves current print position in defined units
ESC D nn	68	44	Set Horizontal Tabs Up to 32 tabs (1-255) entered in ascending order Terminated by 0
HT	9	09	Tab Horizontally

ASCII	Dec.	Hex.	Description
ESC B <i>nn</i>	66	42	Set Vertical Tabs Up to 16 tabs (1-255); last <i>n</i> should be 0
VT	11	0B	Tab Vertically
ESC J <i>n</i>	74	4A	Perform <i>n</i> /180-inch Line Feed

### Font selection

ASCII	Dec.	Hex.	Description
ESC k <i>n</i>	107	6B	Select Typeface <i>n</i> = 0: Roman 5: OCR-B 1: Sans Serif 7: Orator 2: Courier 8: Orator-S 3: Prestige 9: Script C 4: Script
ESC X <i>nm</i>	88	58	Select Font by Pitch and Point ESC X <i>m n1 n2</i> <i>m</i> : Set pitch to 360/ <i>m</i> cpi <i>m</i> = 0 : No change in pitch <i>m</i> = 1 : Select proportional <i>m</i> = 0, 1, 18, 21, 24, 30, 36, 42, 48, 60, or 72 <i>n</i> : Set point size in 0.5 points Total points = ( <i>n1</i> + <i>n2</i> × 256) × 0.5 <i>n</i> = 0 : No change in point <i>n</i> = 0, 16, 20, 21, 24, 28, 32, 36, 40, 42, 44, 48, 52, 56, 60, or 64 (for Roman and Sans Serif) <i>n</i> = 0, 21, 42 (for other typefaces)

- Cancel ESC X with ESC I', M, g, p, !, or @

ASCII	Dec.	Hex.	Description
ESC P	80	50	Select 10.5 point, 10 cpi
ESC M	77	4D	Select 10.5 point, 12 cpi
ESC g	103	67	Select 10.5 point, 15 cpi
ESC p 1/0	112	70	Turn Proportional Mode On/Off
ESC x n	120	78	Select Letter Quality or Draft n = 0: Draft 1: Letter Quality
ESC 4	52	34	Select Italic Font
ESC 5	53	35	Cancel Italic Font
ESC E	69	45	Select Bold Font
ESC F	70	46	Cancel Bold Font
ESC ! n	33	21	Master Select To find the value of n add together the numbers of the tpestyles you want to combine from the list below: n = 0: 10 cpi 1: 12 cpi 2: proportional 4: condensed 8: bold 16: double-strike 32: double-width 64: italic 128: underline

**Font enhancement**

ASCII	Dec.	Hex.	Description
SI	15	0F	Select Condensed Printing
DC2	18	12	Cancel Condensed Printing
s o	14	0E	Select Double-Width Printing (one line)
ESC W 1/0	87	57	Turn Double-Width Printing On/Off
DC4	20	14	Cancel Double-Width Printing (one line)
ESC w 1/0	119	77	Turn Double-Height Printing On/Off
ESC G	71	47	Select Double-Strike Printing
ESC H	72	48	Cancel Double-Strike Printing
ESC S 0	83	53	Select Superscript Printing
ESC S 1	83	53	Select Subscript Printing
ESC T	84	54	Cancel Superscript/Subscript Printing
ESC ( - nn	40 45 28	2D	Select Line/Score ESC ( - 3 0 1 n1 n2 n1 = 1: Underline n1 = 2: Strikethrough n1 = 3: Overscore n2 = 0: Cancel score line selected by n1 n2 = 1: Single continuous line n2 = 2: Double continuous line n2 = 5: Single broken line n2 = 6: Double broken line
ESC - 1/0	45	2D	Turn Underline On/Off
ESC q n	113	71	Select Character Style n = 0: Normal style 1: Outline 2: Shadow 3: Outline with shadow

## Spacing

ASCII	Dec.	Hex.	Description
ESC SP n	32	20	Set Intercharacter Space n = number of units of space added to the space between characters (1-127) Units are 1/120 inch (draft) and 1/180 inch (LQ and proportional)
ESC ( U nn	40 85	28 55	Define Unit ESC ( U 10 n Define positioning unit as n/3600 inch n = 10, 20, 30, 40, 50, or 60 n = 10; default
ESC c n1 n2	99	63	Set Horizontal Motion Index (HMI) Change Pitch in n/360-inch units Total units = n1 + n2 x 2 5 6

## Character handling

ASCII	Dec.	Hex.	Description
ESC ( t nn	40	28	Assign Character Table ESC ( t 3 0 d1 d2 d3 Assign Character Table set by d2 and d3 to d1 d1 = 0, 1, 2, 3, "0", "1", "2", or "3" d2 d3 Character Table 0 0 Italic 1 0 PC 437 (USA) 3 0 PC 850 (Multilingual) 7 0 PC 860 (Portugal) 8 0 PC 863 (Canada-French) 9 0 PC 865 (Norway)

## Commands *Arranged by Topic*

ASCII	Dec.	Hex.	Description
ESC t <i>n</i>	<b>116</b>	<b>74</b>	Select Character Table Select character table <i>n</i> assigned by ESC ( t <b>n = 0, 1, 2, 3, "1", "2", or "3"</b> <b>n = 2:</b> Remaps downloaded characters from O-127 to 128-255
ESC R <i>n</i>	<b>82</b>	<b>52</b>	Select <b>an</b> International Character Set <b>n = 0:</b> USA <b>8:</b> Japan <b>1:</b> France <b>9:</b> Norway <b>2:</b> Germany <b>10:</b> Denmark II <b>3:</b> UK <b>11:</b> Spain II <b>4:</b> Denmark <b>12:</b> Latin America <b>5:</b> Sweden <b>13:</b> Korea <b>6:</b> Italy <b>64:</b> Legal <b>7:</b> Spain
ESC & <i>nn</i>	<b>38</b>	<b>26</b>	Define User-Defined Character ESC & 0 <i>n1 n2 d0 d1 d2</i> data <i>n1</i> = first character number <i>n2</i> = last character number <i>d0</i> = left space of character <i>d1</i> = body width of character <i>d2</i> = right space of character data: 3 bytes required for each column; super/subscripts require only 2 bytes per column
ESC : 0 <i>n</i> 0	<b>58</b>	<b>3A</b>	Copy ROM to RAM <b>n = 0, 1, 2, 3, 4, 5, or 9</b> <b>n :</b> Typeface
ESC % <i>n</i>	<b>37</b>	<b>25</b>	Select User-Defined Set <b>n = 0:</b> Normal set <b>1:</b> User-defined set
ESC 6	<b>54</b>	<b>36</b>	Enable Printing of Upper Control Codes With Extended Graphics this command enables the printing of codes 128-159

ASCII	Dec.	Hex.	Description
ESC 7	55	37	Enable Upper Control Codes Cancels ESC 6
ESC (^nn	40 94	28 5E	Print Data as Characters ESC (^ n1 n2 data n = n1 + n2 x 256 n: amount of data data: n byte data for printing as character

### Bit image

ASCII	Dec.	Hex.	Description
ESC * n n	42	2A	Select Bit Image ESC * m n1 n2 data n = n1 + n2 x 256 n: Total columns Total data = (n1 + n2 x 256) x t

<i>m</i>	Horizontal density (dpi)	Vertical density (dpi)	Pins	Adjacent dots printing	<i>t</i>
0	60	60	8	enable	1
1	120	60	8	enable	1
2	120	60	8	disable	1
3	240	60	8	disable	1
4	80	60	8	enable	1
6	90	60	8	enable	1
32	60	180	24	enable	3
33	120	180	24	enable	3
38	90	180	24	enable	3
39	180	180	24	enable	3
40	360	180	24	disable	3



## Graphics

ASCII	Dec.	Hex.	Description
ESC ( G <i>nn</i> 40 7 1	28 47		Select Graphics Mode ESC ( G 1 0 <i>n</i> <i>n</i> = 1, or 49

- Cancel Graphics mode with ESC @

ESC . <i>nn</i>	46	2E	Print Raster Graphics ESC . <i>c v h m n1 n2</i> data <i>c</i> = 0: Full graphics mode 1: Compressed mode <i>v</i> = 10, 20: Dot density for vertical in 3600/ <i>v</i> DPI <i>h</i> = 10, 20: Dot density for horizontal in 3600/ <i>h</i> DPI <i>m</i> : Number of vertical dots Total dots = <i>n1</i> + <i>n2</i> x 256
-----------------	----	----	--

- The following combination is not allowed: *v*=10 and *h*=20

---

# Appendix

Character Tables .....	A-2
Italic Character Table .....	A-2
<b>Graphics Character Tables</b> .....	<b>A-3</b>
International Character Sets .....	<b>A-6</b>

## Character Tables

These character tables are selected by setting DIP switches 1-1, 1-2, 1-3, and 1-4, or by using the ESC t software command. For the graphics character tables, the ESC 6 and ESC 7 software commands let you select whether hex codes 80 to 9F are characters (ESC 6) or control codes (ESC 7).

### Italic Character Table

CODE	0	1	2	3	4	5	6	7	8	9	A	B	C	D	E	F
0	NUL		SP	0	@	P	`	p	NUL		SP	0	@	P	`	p
1			!	1	A	Q	a	q			!	1	A	Q	a	q
2		DC2	"	2	B	R	b	r		DC2	"	2	B	R	b	r
3			#	3	C	S	c	s			#	3	C	S	c	s
4		DC4	\$	4	D	T	d	t		DC4	\$	4	D	T	d	t
5			%	5	E	U	e	u			%	5	E	U	e	u
6			&	6	F	V	f	v			&	6	F	V	f	v
7			'	7	G	W	g	w			'	7	G	W	g	w
8			(	8	H	X	h	x			(	8	H	X	h	x
9	HT	EM	)	9	I	Y	i	y	HT	EM	)	9	I	Y	i	y
A	LF		*	:	J	Z	j	z	LF		*	:	J	Z	j	z
B	VT	ESC	+	;	K	[	k	{	VT	ESC	+	;	K	[	k	{
C	FF		,	<	L	\	l	!	FF		,	<	L	\	l	!
D	CR		-	=	M	]	m	~	CR		-	=	M	]	m	~
E	SO		.	>	N	^	n		SO		.	>	N	^	n	
F	SI		/	?	O	_	o		SI		/	?	O	_	o	

Graphics Character Tables

PC 437 (United States) character table

CODE	0	1	2	3	4	5	6	7	8	9	A	B	C	D	E	F
0	NUL		SP	0	@	P	`	p	Ç	É	Á	á	␣	␣	α	≡
1			!	1	A	Q	a	q	ü	æ	í	í	␣	␣	β	±
2		DC2	"	2	B	R	b	r	é	Æ	ó	ó	␣	␣	Γ	≥
3			#	3	C	S	c	s	â	ô	ú	ú	␣	␣	Π	≤
4		DC4	\$	4	D	T	d	t	ä	ö	ñ	ñ	␣	␣	Σ	∫
5		§	%	5	E	U	e	u	à	ò	Ñ	Ñ	␣	␣	σ	∫
6			&	6	F	V	f	v	ã	û	ã	ã	␣	␣	μ	÷
7			'	7	G	W	g	w	ç	ÿ	ö	ö	␣	␣	τ	°
8			(	8	H	X	h	x	ê	ÿ	Ö	Ö	␣	␣	ϕ	°
9	HT	EM	)	9	I	Y	i	y	ë	ÿ	Ö	Ö	␣	␣	θ	°
A	LF		*	:	J	Z	j	z	è	ÿ	Ü	Ü	␣	␣	Ω	°
B	VT	ESC	+	;	K	[	k	{	ï	ÿ	Φ	Φ	␣	␣	δ	°
C	FF		,	<	L	\	l	}	î	ÿ	£	£	␣	␣	ø	°
D	CR		-	=	M	]	m	~	ï	ÿ	¥	¥	␣	␣	∅	°
E	SO		.	>	N	^	n		ÿ	ÿ	«	«	␣	␣	ε	°
F	SI		/	?	O	_	o		ÿ	ÿ	»	»	␣	␣	∞	°

PC 850 (Multilingual) character table

CODE	0	1	2	3	4	5	6	7	8	9	A	B	C	D	E	F
0	NUL		SP	0	@	P	`	p	Ç	É	Á	á	␣	␣	Ó	-
1			!	1	A	Q	a	q	ü	æ	í	í	␣	␣	ø	±
2		DC2	"	2	B	R	b	r	é	Æ	ó	ó	␣	␣	ð	±
3			#	3	C	S	c	s	â	ô	ú	ú	␣	␣	ê	±
4		DC4	\$	4	D	T	d	t	ä	ö	ñ	ñ	␣	␣	ë	±
5		§	%	5	E	U	e	u	à	ò	Ñ	Ñ	␣	␣	è	±
6			&	6	F	V	f	v	ã	û	ã	ã	␣	␣	í	±
7			'	7	G	W	g	w	ç	ÿ	ö	ö	␣	␣	î	±
8			(	8	H	X	h	x	ê	ÿ	Ö	Ö	␣	␣	ï	±
9	HT	EM	)	9	I	Y	i	y	ë	ÿ	Ü	Ü	␣	␣	ú	±
A	LF		*	:	J	Z	j	z	è	ÿ	Ü	Ü	␣	␣	û	±
B	VT	ESC	+	;	K	[	k	{	ï	ÿ	ø	ø	␣	␣	ü	±
C	FF		,	<	L	\	l	}	î	ÿ	£	£	␣	␣	ý	±
D	CR		-	=	M	]	m	~	ï	ÿ	¥	¥	␣	␣	ÿ	±
E	SO		.	>	N	^	n		ÿ	ÿ	«	«	␣	␣	ÿ	±
F	SI		/	?	O	_	o		ÿ	ÿ	»	»	␣	␣	ÿ	±

PC 860 (Portugal) character table

CODE	0	1	2	3	4	5	6	7	8	9	A	B	C	D	E	F
0	NUL		SP	0	@	P	`	p	Ç	É	á	í	l	l	α	≡
1			!	1	A	Q	a	q	ü	È	â	ó	l	l	β	≡
2		DC2	"	2	B	R	b	r	é	Ê	ô	ó	l	l	Γ	≡
3			#	3	C	S	c	s	â	Ô	ú	ñ	l	l	Π	≡
4		DC4	\$	4	D	T	d	t	ã	Ö	õ	ñ	l	l	Σ	≡
5		S	%	5	E	U	e	u	à	ò	ô	Ñ	l	l	σ	≡
6			&	6	F	V	f	v	Á	Ú	ó	o	l	l	μ	≡
7			'	7	G	W	g	w	Ç	ù	ì	o	l	l	τ	≡
8			(	8	H	X	h	x	ê	Ë	ö	o	l	l	ø	≡
9	HT	EM	)	9	I	Y	i	y	ê	Ë	ö	o	l	l	ø	≡
A	LF		*	:	J	Z	j	z	è	Û	õ	o	l	l	Ω	≡
B	VT	ESC	+	;	K	[	k	{	í	Ü	ç	¼	l	l	δ	≡
C	FF		,	<	L	\	l	l	î	Û	ç	¼	l	l	8	≡
D	CR		-	=	M	]	m	}	ï	Û	ç	¼	l	l	ø	≡
E	SO		.	>	N	^	n	~	ÿ	Û	ç	¼	l	l	ø	≡
F	SI		/	?	O	_	o	o	ÿ	Û	ç	¼	l	l	ø	≡

PC 863 (Canada-French) character table

CODE	0	1	2	3	4	5	6	7	8	9	A	B	C	D	E	F
0	NUL		SP	0	@	P	`	p	Ç	É	á	í	l	l	α	≡
1			!	1	A	Q	a	q	ü	È	â	ó	l	l	β	≡
2		DC2	"	2	B	R	b	r	é	Ê	ô	ó	l	l	Γ	≡
3			#	3	C	S	c	s	â	Ô	ú	ñ	l	l	Π	≡
4		DC4	\$	4	D	T	d	t	ã	Ö	õ	ñ	l	l	Σ	≡
5		S	%	5	E	U	e	u	à	ò	ô	Ñ	l	l	σ	≡
6			&	6	F	V	f	v	Á	Ú	ó	o	l	l	μ	≡
7			'	7	G	W	g	w	Ç	ù	ì	o	l	l	τ	≡
8			(	8	H	X	h	x	ê	Ë	ö	o	l	l	ø	≡
9	HT	EM	)	9	I	Y	i	y	ê	Ë	ö	o	l	l	ø	≡
A	LF		*	:	J	Z	j	z	è	Û	õ	o	l	l	Ω	≡
B	VT	ESC	+	;	K	[	k	{	í	Ü	ç	¼	l	l	δ	≡
C	FF		,	<	L	\	l	l	î	Û	ç	¼	l	l	8	≡
D	CR		-	=	M	]	m	}	ï	Û	ç	¼	l	l	ø	≡
E	SO		.	>	N	^	n	~	ÿ	Û	ç	¼	l	l	ø	≡
F	SI		/	?	O	_	o	o	ÿ	Û	ç	¼	l	l	ø	≡

PC 865 (Norway) character table

CODE	0	1	2	3	4	5	6	7	8	9	A	B	C	D	E	F
0	NUL		SP	0	@	P	`	p	Ç	É	á		⌞	⌞	α	≡
1			!	1	A	Q	a	q	ü	æ	í		⌞	⌞	β	±
2		DC2	"	2	B	R	b	r	é	Æ	ó		⌞	⌞	Γ	≥
3			#	3	C	S	c	s	â	ô	ú		⌞	⌞	π	≤
4		DC4	\$	4	D	T	d	t	ä	ö	ñ		⌞	⌞	Σ	⌞
5		§	%	5	E	U	e	u	à	ò	Ñ		⌞	⌞	σ	⌞
6			&	6	F	V	f	v	å	û	ã		⌞	⌞	μ	÷
7			'	7	G	W	g	w	ç	Û	ø		⌞	⌞	τ	≈
8			(	8	H	X	h	x	ë	ÿ	Ö		⌞	⌞	ϕ	°
9	HT	EM	)	9	I	Y	i	y	è	Û	Ü		⌞	⌞	θ	•
A	LF		*	:	J	Z	j	z	è	Û	Ü		⌞	⌞	Ω	√
B	VT	ESC	+	;	K	L	k	l	ï	î	ø		⌞	⌞	δ	²
C			,	<	L	\	l	l	ï	î	ø		⌞	⌞	ø	²
D	CR		-	=	M	]	m	n	ï	î	ø		⌞	⌞	ø	²
E	SO		.	>	N	^	n	n	ï	î	ø		⌞	⌞	ø	²
F	SI		/	?	O	_	o	o	ï	î	ø		⌞	⌞	ø	²

Character available with ESC (^)

CODE	0	1	7
0		▶	
1	⊕	◀	
2	⊕	↕	
3	♥	!!	
4	♦	π	
5	♣		
6	♠	-	
7	•	↕	
8	■	↑	
9	○	↓	
A	⊙	→	
B	♂	←	
C	♀	└	
D	♪	↔	
E	♫	▲	
F	*	▼	△

To print the characters in the table on the left, you must first send the ESC (^) command. This command is available only on printers featuring Epson ESC/P 2.

## International Character Sets

Country	ASCII code (hex)												DIP switch			
	23	24	40	5B	5C	5D	5E	60	7B	7C	7D	7E	1-1	1-2	1-3	1-4
0 U.S.A.	#	\$	@	[	\	]	^	'	{		}	~	On	On	On	Off
1 France	#	\$	à	°	ç	§	^	'	é	ù	è	¨	On	On	Off	Off
2 Germany	#	\$	§	Ä	Ö	Ü	^	'	ä	ö	ü	ß	On	Off	On	Off
3 United Kingdom	£	\$	@	[	\	]	^	'	{		}	~	On	Off	Off	Off
4 Denmark I	#	\$	@	Æ	Ø	Å	^	'	æ	ø	å	~	Off	On	On	Off
5 Sweden	#	¤	É	Ä	Ö	Å	Ü	é	ä	ö	å	ü	Off	On	Off	Off
6 Italy	#	\$	@	°	\	é	^	ù	à	ò	è	ì	Off	Off	On	Off
7 Spain I	¤	\$	@	;	Ñ	¿	^	'	¨	ñ	}	~	Off	Off	Off	Off

The following seven additional sets are available only by using the ESC R software command.

Country	ASCII code (hex)											
	23	24	40	56	5C	5D	5E	60	7B	7C	7D	7E
8 Japan (English)	#	\$	@	[	¥	]	^	'	{		}	~
9 Norway	#	¤	É	Æ	Ø	Å	Ü	é	æ	ø	å	ü
10 Denmark II	#	\$	É	Æ	Ø	Å	Ü	é	æ	ø	å	ü
11 Spain II	#	\$	á	;	Ñ	¿	é	'	í	ñ	ó	ú
12 Latin America	#	\$	á	;	Ñ	¿	é	ü	í	ñ	ó	ú
13 Korea	#	\$	@	[	₩	]	^	'	{		}	~
64 Legal	#	\$	§	°	'	"	¶	'	©	®	†	™

---

# Glossary

The following definitions apply specifically to printers.

## **application program**

A software program that helps you carry out a particular task, such as word processing or financial planning.

## **ASCII**

American Standard Code for Information Interchange. A standardized coding system for assigning numerical codes to letters and symbols.

## **bidirectional printing**

Printing in which the print head goes from left to right only on every other line. On the other lines, it goes from right to left. This increases the speed of printing because the head prints in both directions.

## **bit**

A binary digit (0 or 1), which is the smallest unit of information used by a printer or computer.

## **buffer**

The portion of the printer's memory used to store data before printing it.

## **byte**

A unit of information consisting of eight bits.

## **character set**

A collection of letters, numbers, and symbols.



**characters per inch (cpi)**

A measure of the size of text characters. Ten cpi is the printer's default setting.

**condensed printing**

Printing in which each character is approximately 60% of the width of standard characters. Useful for fitting wide tables or spreadsheets onto paper.

**continuous paper**

Paper that has sprocket-feed holes on each side, is perforated between pages, and is supplied in a folded stack. Also called fanfold paper.

**control code**

Special codes used to control printer functions such as performing a carriage return or line feed.

**cpi**

See characters per inch.

**cut-sheet feeder (CSF)**

An optional, detachable device that automatically feeds single sheets of paper into the printer.

**data dump**

A troubleshooting feature that helps advanced users find the cause of communication problems between the printer and the computer. When the printer is in data dump mode, it prints each code it receives in hexadecimal notation and ASCII characters. Also called hex dump.

**default**

A value or setting that takes effect when the equipment is turned on, reset, or initialized.

**DIP switches**

Small switches in a printer that control various printer functions and set the default status of the printer when it is turned on or initialized. DIP stands for dual in-line package.

**dot matrix**

A method of printing in which each letter or symbol is formed by a pattern (matrix) of individual dots.

**double-height printing**

Printing in which each character is twice as tall as normal.

**double-width printing**

Printing in which each character is twice as wide as normal.

**draft**

One of three print qualities available on your printer. Draft uses a minimum number of dots per character for high-speed printing. See also high-speed *draft* and Letter Quality.

**ESC/P 2**

The enhanced version of the ESC/P printer command language. Commands in this language give laser-like features, such as scalable fonts and enhanced graphics printing.

**ESC/P**

Abbreviation for Epson Standard Code for Printers. This system of commands gives you software control of your printer from your computer. It is standard for all Epson printers and supported by most application software for personal computers.

**font**

A font is a style of type designated by a family name.

**form feed**

A control code and control panel button that advance the paper to the next top-of-form position.

**high-speed draft**

One of three print qualities available on your printer. High-speed draft uses a minimum number of dots per character to produce extremely high-speed printing. See also draft and Letter Quality.

**initialize**

To establish the initial default status of **the** printer by turning on the printer or sending an INIT signal.

**interface**

The connection between the computer and the printer. A parallel interface transmits data one character or code at a time, and a serial interface transmits data one bit at a time.

**italics**

A typestyle in which the characters slant. This sentence is italicized. Also, a character table that contains italicized characters and symbols.

**Letter Quality (LQ)**

One of three print qualities available on your printer. Letter quality provides better readability and appearance at a reduced print speed. See also draft and high-speed draft.

**line feed**

A control code and control panel button that advance the paper one line space.

**loading position**

The position to which **the** paper is automatically loaded. It can be adjusted with the micro-feed feature.

**micro feed**

A feature that you use to adjust the paper loading and tear-off positions, and a control panel button you use to feed paper, either forward or backward, in 1/180-inch increments.

**parallel interface**

See **interface**.

**platen**

The black roller that provides a backing for the paper during printing.

**printable area**

The area of a page on which the printer can print. It is smaller than the physical size of the page due to margins.

**proportional printing**

Printing in which the width of the character varies from character to character. For example, a capital W receives much more space than a lowercase i. The result looks more like a typeset book than a typewritten draft.

**RAM**

Random access memory. The portion of the printer's memory used as a buffer and for storing user-defined characters. All data stored in RAM is lost when the printer is turned off.

**reset**

To return a printer to its default status by sending a command or an INIT signal or by turning the printer off and then back on.

**self test**

A method for checking the operation of the printer. When you run the self test, the printer prints its current DIP-switch settings and the characters stored in its ROM.

**standby position**

The position in which the paper is attached to the push tractor but not in the paper path.

**subscript**

Printing in which **each** character is printed at about two-thirds the normal height in the lower part of the character space.

**superscript**

Printing in which each character is printed at about two-thirds the normal height in the upper part of the character space.

**tear off**

A control panel button that automatically feeds the perforation of continuous paper to the tear-off position and then feeds the paper back to the loading position.

**tear-off position**

The position the printer feeds the paper to when you press the **TEAR OFF** button or when auto tear-off mode is on. Using the micro-feed feature, you can adjust the position so that the paper's perforation meets the printer's tear-off edge.

**top of form**

The position on the paper that the printer recognizes as the first printable line. The printer feeds the paper to this position when it loads the paper.

**unidirectional printing**

Printing in one direction only. Unidirectional printing is useful for printing graphics because it allows more precise vertical alignment than bidirectional printing.

**user-defined characters**

Characters that are defined and stored in the printer by the user. Also known as downloaded characters.

---

# Index

Command descriptions are not indexed here. For information on a specific command, see Chapter 8.

- A
- Adjusting the loading position, 3-14
  - Application software, 1-14
  - Auto line feed, 3-7, 3-12
- B
- Baud rate, 4-16
  - Bidirectional printing, 3-7, 3-10
  - Buffer, 3-7, 3-10, 7-3
  - Buffer clear, 3-4, 6-7
  - Buttons, 3-3
- C
- Cable
    - parallel interface, 1-13
  - Character
    - fonts, 3-4, 3-19, 7-3
    - pitch, 3-23, 7-3
    - tables, 3-7-9, A-2-5
  - Cleaning the printer, 5-2
  - Connecting the printer, 1-13
  - Continuous paper
    - loading, 2-12-19
    - top of form, 2-19, 3-14
  - Control panel, 3-2
  - Copy capacity, 2-24
  - Cut-sheet feeder, 2, 3-2-3, 4-2-11
    - double-bin, 2, 4-2, 4-9-10
    - high-capacity, 2, 4-2-3, 4-6-8
    - single-bin, 2, 4-2-5
- D
- Data dump, 3-24
  - Default settings, 7-16
  - DIP switches,
    - functions, 3-9-12
    - setting, 3-6
    - tables, 3-7-8
  - Draft, 3-7, 3-10, 3-20
    - high-speed, 3-7, 3-10, 3-20
- E
- Edge guides, 4, 1-11, 2-5, 2-14, 4-5
    - front, 2-7, 2-17
  - EJECT button, 3-3
  - Envelopes, 2-24, 2-26, 4-8, 7-4, 7-6
    - cut-sheet feeder, 4-6, 4-8
    - loading, 2-26

## F

- FF button, 3-3
- Fonts, 3-4, 3-19, 7-3
  - button, 3-4
  - draft, 3-7, 3-10, 3-20
  - Epson Courier, 3-20
  - Epson Orator, 3-22
  - Epson Orator-S, 3-22
  - Epson Prestige, 3-21
  - Epson Roman, 3-20-21
  - Epson Sans Serif, 3-21
  - Epson Script, 3-21
  - Epson Script-C, 3-22
  - high-speed draft, 3-7, 3-10, 3-20
  - OCR-B, 3-22
- Form length
  - continuous paper, 3-7-8

## G

- Graphics character table, A-2

## H

- High-speed draft, 3-7, 3-10, 3-20

## I

- Initialization, 7-16
- Input buffer, 3-7, 3-10, 7-3
- Interface
  - optional, 2, 4-14
  - specifications, 7-10
- International character sets, A-6
- Italic character table, A-2

## L

- Labels, 2-25, 7-6
- Letter Quality, 3-19
- LF button, 3-3
- LOAD button, 3-3
- Loading paper, 2-4, 2-12, 2-15
  - continuous paper, 2-12, 2-15
  - cut-sheet feeder, 4-3, 4-6
  - envelopes, 2-26, 4-6
  - labels, 2-25
  - single sheets, 2-4
- Loading position, 3-14

## M

- Micro-feed feature, 3-13
- Multi-part forms, 2-24
- MULTI-PART light, 3-2

## O

- OCR-B font, 3-22
- OPERATE light, 3-2
- Options, 2, 4-1, 6-10, 7-14
  - cut-sheet feeder, 2, 4-2, 7-14
  - interface card, 2, 4-14
  - pull tractor, 2, 4-12

## P

- Paper guide, 4, 1-9
- PAPER OUT light, 3-2
- Paper-release lever, 2-2, 2-9, 4-12
- Paper-thickness lever, 2-23
- Parallel interface, 4-14, 7-10

**PAUSE** button, 3-3  
Plugging in the printer, 1-10  
Printable area, 7-5  
Print direction, 3-7, 3-10  
Problems, see Troubleshooting  
Protective materials  
    replacing, 5-4  
    removing, 1-5  
Pull tractor, 2-3, 2-11, 2-15,  
    4-12  
Push tractor, 2-3, 2-10, 2-12

## **R**

Ribbon cartridge  
    fabric, 1-2, 5-3, 7-7  
    film, 2, 5-3, 7-7  
    installing, 1-6  
    specifications, 7-7

## **S**

Safety instructions, v  
Scalable fonts, 3-19  
Self test, 1-10  
Single sheets, 2-4-8  
Skip-over-perforation, 3-7, 3-11  
Special paper, 2-23  
Specifications, 7-1

## **T**

**TEAR OFF** button, 3-4  
    light, 3-3  
Tear off, 3-7, 3-11, 3-16  
    mode, 3-7, 3-11, 3-16  
    position, 3-18

Tractor, 2-9  
    installing, 2-9-11  
    position, 2-9  
Transporting the printer, 5-4  
Troubleshooting, 6-1-12  
Typestyles, 3-19

## **U**

Unidirectional printing, 3-7,  
    3-10  
Unpacking the printer, 1-2

## **V**

Voltage, 1-10  
    power supply, 1-10

## **W**

Weight, 7-6-7, 7-14





## **KEY FEATURES**

---

- ❑ Sharp letter quality text and graphics printing
- ❑ Fast 315 CPS draft print speed
- ❑ Eleven popular built-in LQ fonts
- ❑ Top, rear, front, and bottom paper feed paths
- ❑ Easy-to-operate front control panel
- ❑ Efficient, advanced paper handling system
- ❑ Versatile, reliable high-resolution printing  
backed by Epson two-year limited warranty

## **EPSON AMERICA, INC.**

---

20770 Madrona Avenue, Torrance, CA 90503